

Dear Referee,

We would like to thank you for your professional and constructive comments concerning our manuscript entitled "Assessment of the physical vulnerability of buildings affected by slow-moving landslides". These comments are all valuable and helpful for revising and improving our manuscript. We have seriously considered and provided our point-by-point responses, which are listed below.

Specific comments:

(1) In Section 2.2.1 the Authors recall the equivalent elastic beam – originally introduced by Burland and Wroth (1974) to define a damageability criterion – in order to compute the maximum deflection exhibited by the same beam under a uniform load whose modulus equals q . In Figure 2 this uniform load acts horizontally, in correspondence of the lateral surface of the building's foundation affected by the landslide; whereas in Figure 3 the uniform load is applied vertically to the elastic beam. Accordingly, it is not clear in which direction the maximum deflection develops. Furthermore, symbols adopted in Figures 2 and 3 to denote the geometrical characteristics of the building's foundation are not internally consistent. Could the Authors better explain?

Response: thank you very much for the comment. In Figure 3, we actually try to express the uniform load applied horizontally, so sorry for the confusing. We plan to revise the figure 3 as follows.

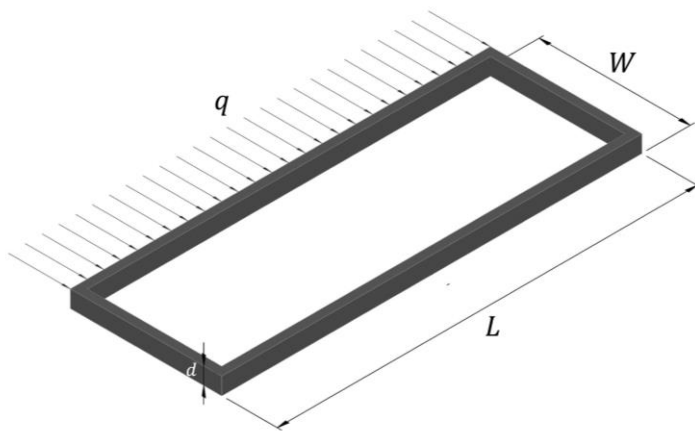

Fig.3 The simple beam with its foundation affected by landslide thrust.

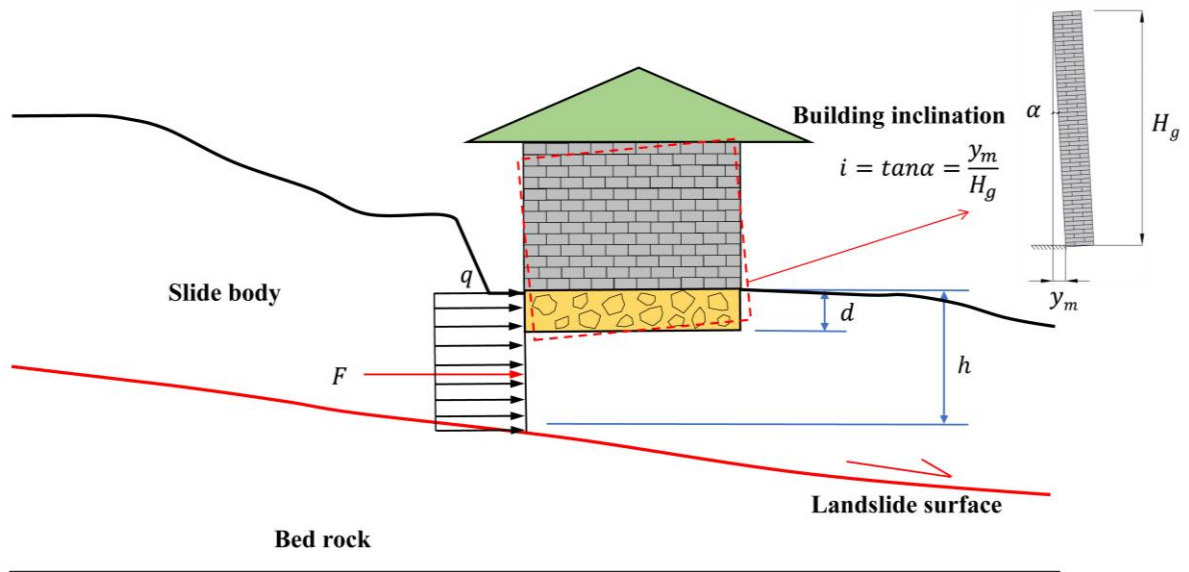

Fig. 2. Schematic diagram of landslide thrust action on a building.

where q denotes the distribution force on the foundation (kN/m), F denotes the horizontal component of landslide residual thrust (P_i) in Eq. (3), and h denotes the vertical distance from sliding surface to the ground surface. i denotes the inclination of the building, which is the ratio of the maximum horizontal deformation y_m to the height H_g of the building calculated from the outdoor ground (Fig.2). L , W , and d denote the length, width and depth of the building foundation (Fig.3).

(2) In the same Section 2.2.1 the concept of “inclination” of a building is introduced. Does this inclination corresponds to the “rotation” or “slope” (i.e. the change in gradient of a line joining two reference points of the foundation base) or to the “tilt” (describing the rigid body rotation of the whole superstructure or a well-defined part of it) defined by Burland and Wroth (1974)? Or does it refer to another well-defined parameter? Please clarify. I also suggest to associate the Eq. (9) – used to express mathematically the concept of inclination – with a Figure helpful to better understand the meaning of symbols adopted in Eq. (9), including the angle alpha.

Response: thank you very much for the suggestion. The concept of “inclination” in our manuscript is that the ratio of the difference y_m (between the top and bottom of the building) to the height H_g of the building. In some references, such as researches by Li (2010), this concept is used for “inclination”. We inserted a figure in Fig.2 to better understand the meaning of symbols adopted in Eq. (9) as follow.

Reference

1. Li, Z., Nadim, F., Huang, H., Uzielli, M., and Lacasse, S.: Quantitative vulnerability estimation for scenario-based landslide hazards, *Landslides*, doi:10.1007/s10346-009-0190-3, 2010

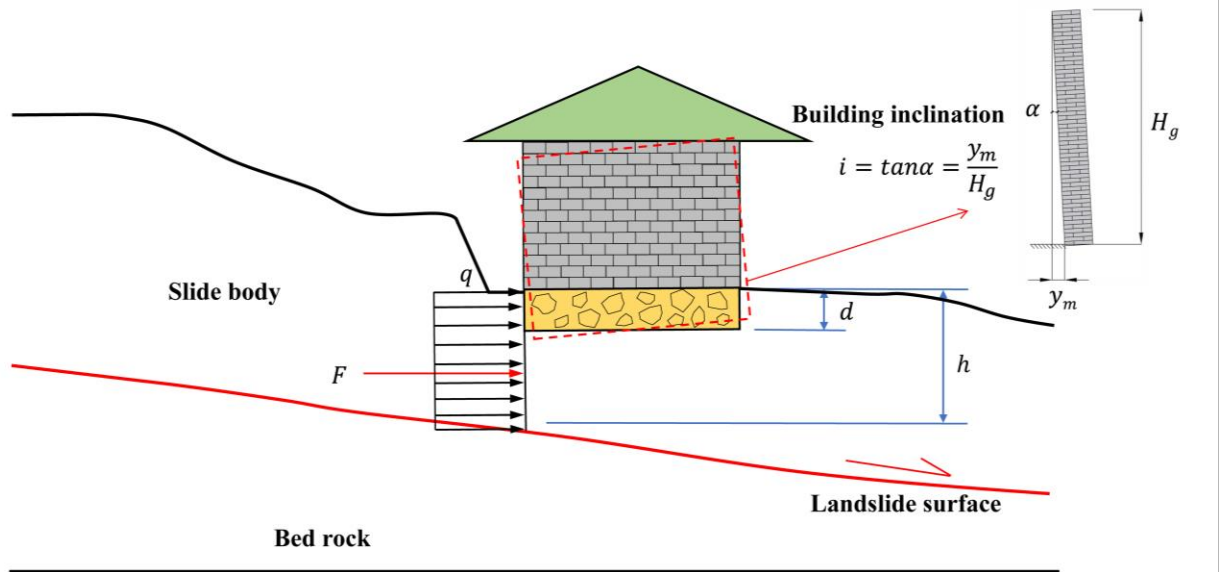

Fig. 2. Schematic diagram of landslide thrust action on a building.

(3) In Table 3 the shear strength parameters of soils involved in the shear zone of the Manjiapo landslide are summarized. Are they residual shear strength values? And, more in general, what type of laboratory tests was carried out? Please explain.

Response: thank you very much for the comment. The shear strength parameters in Table 3 are residual values. According to the report provided by the China Geological Survey (Hunan Institute of Xiangxi Geological Engineering Survey) in 2017, six groups of undisturbed soil samples were collected from the shear zone of the Manjiapo Landslide. Obtained by residual shear tests in the laboratory, the shear strength parameters of slip soils in Table 3 are the average values of these six groups of soil samples.

(4) In Table 4 it is not clear if the Young's modulus refers to the masonry constituting the building superstructure or to the material constituting the building foundation. Please clarify.

Responses: Thank you very much for your comments. The Young's modulus in Table 4 refers to the material constituting the building foundation. We will revise Table 4 as follows.

Table 4. Parameters of the case building and its foundation on the Manjiapo landslide

For building			For foundation				Soil depth where the building located (m)
Length L (m)	Width W (m)	Height H_g (m)	Depth d (m)	Young's modulus E (MPa)	Shear modulus G (MPa)	E/G	
25	9	2.8	1	2250	865	2.6	5

(5) In Section 4.1 the rainfall scenarios considered for transient seepage analyses are introduced. However, relevant information is provided neither on the fixed boundary conditions nor on the adopted hydraulic conductivities. Please improve this Section.

Response: thank you very much for the suggestion. We use the SEEP/W code (GEOSTUDIO) to analyze the groundwater seepage of Manjiapo landslide. We obtain the amount of 3-day cumulative precipitation corresponding to each return period by using PT (Pearson type) III distribution model and the rainfall data (Fig. 11). The average amount of 3-day cumulative precipitation is input to the software in turn, and then the groundwater under the rainfall scenarios is simulated.

The saturated volumetric water content is 0.4 by cutting ring method. The saturated permeability coefficient is obtained by back analysis. We choose the saturated volumetric water content and the permeability coefficient by the variable-controlling approach. Three groups of input values are: 0.4, 0.1; 0.4, 0.2; 0.4, 0.3. Then, the groundwater is simulated and then validated for the rainfall event in March 2018. The root mean square error (RMSE) is utilized to check the accuracy of calculation. Lower RMSE means smaller error and better prediction effect. The results of RMSE are shown in the following table. We find the saturated volumetric water content is 0.4 and the most suitable value of permeability coefficient is 0.3 m/d.

Permeability coefficient back analysis of the rainfall event in March 2018, by comparing the root mean square errors (RMSE) of for three hydrological gauges (installed by the authors in December 2017, see Fig.5) on Manjiapo landslide

The permeability coefficient (m/d)	0.1	0.2	0.3
RMSE (STK-1)	2.280	2.222	2.154
RMSE (STK-2)	0.860	0.677	0.615
RMSE (STK-3)	2.540	2.491	2.405

Note: the saturated volumetric water content by Lab test is 0.4.

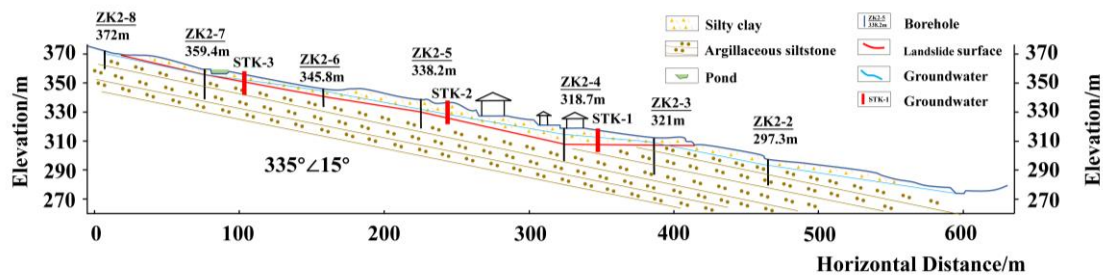

Fig. 5. Geological profile of I-I' of the Manjiapo landslide (1:1 000).

(6) In Table 5 the results obtained for the four considered rainfall scenarios are summarized. In all the cases, the factor of safety (F_s) is lower than 1. This would imply that the landslide is always moving, in disagreement with the information gathered by the Authors about the cracks on the ground surface of the Manjiapo landslide. In particular, the Authors observe that “Meanwhile, since the extreme rainfall events were recently rare, the deformation of the landslide did not obviously change, which was similar to the deformation situation in June 2016. For example, the cracks on the landslide did not expand, and the number of new cracks was very few” (page 10 – lines from 249 to 252). Probably, the shear strength parameters used for

the limit equilibrium analyses are too low (see Table 3) and should be compared with those deriving from the back-analysis of the event occurred on June 2016.

Response: thank you very much for the suggestion. The factor of safety (F_s) in the original Table 5 is for the area where the target building is located, but not for the whole landslide. This is pointed out by the sentence from line 184 to 185 on page 8. To avoid confusing, we revised this variable to be F_{sb} . In addition, we add the results of safety factors for the whole landslide under four scenarios in table 5 as follows. Now in this table, F_s refers to the factor safety of the whole landslide. From table 5, we find that the landslide is stable with factor of safety 1.457.

Table 5. Landslide residual thrust, pushing force on the building's foundation, and damage degree of the building based on four scenarios: (a) dry condition without earthquake, (b) rainfall with a return period of 5 years (3-day precipitation 235 mm/d from Fig. 11), (c) rainfall with a return period of 10 years (3-day precipitation 279 mm/d from Fig. 11) without earthquake, and (d) rainfall with a return period of 50 years (3-day precipitation 352 mm/d from Fig. 11) without earthquakes.

Scenarios	F_{sb}	F_s	F(KN/m)	q (KN/m)	i (%)	V
a	0.853	1.457	142	28	0.053	0.053
b	0.529	0.819	1756	351	0.656	0.656
c	0.481	0.778	2040	408	0.762	0.762
d	0.428	0.632	2638	528	0.985	0.985

Note: F_{sb} is the safety factor of the area where the target building is located.

(7) In Section 4.2 the results of the vulnerability analysis concerning a selected building within the affected area of the Manjiapo landslide are presented. Focusing on the obtained vulnerability curve (Fig. 12) the Authors observe that “the physical vulnerability is very low when the landslide is stable with a safety factor greater than 1.0” (lines from 326 to 327). How is this observation justifiable? Indeed, it is expected that the building vulnerability equals 0 (no damage) if the landslide does not move. In this regard, are the Authors sure that the chosen Weibull (1951) function is the best one to mathematically express the vulnerability curve when $1/FS$ is adopted as landslide intensity parameter?

Response: thank you very much for the comment. For slow-moving landslides, they can have a F_s greater than 1.0 but with cracks within the landslide area. According to the standard of *Code for geological investigation of landslide prevention* (GB/T32864~2016), when the whole landslide has F_s value from 1.0 to 1.05, the landslide will have small scale deformation or cracks. While the buildings located across the cracks can have damages with a certain degree. In the Three Gorges Reservoir area, China (Chen et al., 2016) and other areas, such as Moio della Civitella (Salerno province, Italy) (Infante et al., 2016), the buildings on the huge, slow-moving landslides will appear this state. So, to solve the problem on building's vulnerability, we need to focus on the local stability of this kind of landslide like Manjiapo landslide, but not the whole body. In Figure 12, the F_s value is for the local stability of the soil where the case building located. Following the above question, we need to modify F_s in Figure 12 to be F_{sb} . We can find from Figure 12 and Figure 15 that, when $1.0 < F_{sb} < 1.05$, the

building vulnerability is from 0 to 0.1. This means the building is damaged very slightly, which is consistent with the real state of buildings on slow-moving landslides.

In this regard, we are sure that Weibull function is suitable to express the vulnerability curve. In fact, Weibull function is used to express the vulnerability curve in many present literatures, such as Dario Peduto et (2017), Kang et (2016), Papatoma-Köhle (2016), Negulescu et (2010).

Reference

1. Chen, L., Cao, X., Yin, K., Wu, Y., and Li, Y.: Physical vulnerability assessment for buildings impacted by a slow moving landslide based on field work and statistical modelling, in: Landslides and Engineered Slopes. Experience, Theory and Practice, 2016.
2. Infante, D., Confuorto, P., Di Martire, D., Ramondini, M. and Calcaterra, D.: Use of DInSAR Data for Multi-level Vulnerability Assessment of Urban Settings Affected by Slow-moving and Intermittent Landslides, *Procedia Engineering*, 158, 470–475, doi:10.1016/j.proeng.2016.08.474, 2016.
3. Peduto, D., Ferlisi, S., Nicodemo, G., Reale, D., Pisciotta, G., and Gullà G.: Empirical fragility and vulnerability curves for buildings exposed to slow-moving landslides at medium and large scales, *Landslides*, doi:10.1007/s10346-017-0826-7, 2017.
4. Kang, H. sub and Kim, Y. tae: The physical vulnerability of different types of building structure to debris flow events, *Natural Hazards*, 80(3), 1475–1493, doi:10.1007/s11069-015-2032-z, 2016.
5. Papatoma-Köhle, M.: Vulnerability curves vs. Vulnerability indicators: Application of an indicator-based methodology for debris-flow hazards, *Natural Hazards and Earth System Sciences*, doi:10.5194/nhess-16-1771-2016, 2016.
6. Negulescu, C. and Foerster, E.: Parametric studies and quantitative assessment of the vulnerability of a RC frame building exposed to differential settlements, *Nat. Hazards Earth Syst. Sci.*, 10(9), 1781–1792, 2010.

(8) In the Discussion, the Authors stress that “the physical vulnerability is inversely proportional to the building height” (line 384). This is not in agreement with thresholds values of the building inclination summarized in Table 2. Indeed, as the building height (from the outdoor ground) increases the threshold value decreases.

Response: thank you very much for the comment. Table 2 expresses threshold values of the building inclination for three types of buildings with different height. In this manuscript, we focus on the first class of building with height lower than 24 m, which are common residential buildings in rural areas of China. As to this kind of building, the threshold is a fixed value 1% and the physical vulnerability is inversely proportional to the building height according to the result form Figure 13c.

Table 2. The threshold value of building inclination (Ministry of Housing and Urban–Rural Development of PRC, 2016).

Height H_g (m)	$H_g \leq 24$	$24 < H_g \leq 60$	$60 < H_g \leq 100$
------------------	---------------	--------------------	---------------------

Threshold value i_m	1%	0.7%	0.5%
-----------------------	----	------	------

(9) In my opinion, the vulnerability curves shown in Figure 15 have to be further validated before applying them in analyses at regional scale (lines from 403 to 408).

Response: thank you very much for the good comment. We are currently doing the researches on regional scale slow-moving landslide risk assessment in the Three Gorges reservoir area, China, which involves regional scale vulnerability assessment for buildings. We totally agree with you that before applying the results from this manuscript, we will do further validation.

We tried our best to improve the manuscript and made changes in the manuscript. We feel great thanks for your professional review work on our article, and hope that the responses will meet with approval.

Sincerely,
Lixia Chen