

Dear Editor,

Please find below our point-to-point answers to all the comments of the reviewers and detailed description of all changes in the new version of the manuscript, followed by a marked-up manuscript version.

Best regards,
Ulpu Leijala

Referee Comments #1

Comment	Authors response and changes in manuscript
Major points	
1. In page 9, it is written: "The exponential function was fitted to sea levels with a frequency of exceedance of 5 events/year or less." Why? The frequency of exceedance of the observed data in Figure 4 is from 1/46 to about 8000 events/year. It is thought that only the data of low frequency of exceedance are used in the curve fitting because we are interested in the events of high sea level. The reason why the data of low frequency of exceedance are used should be explained.	<p>The exponential function was applied to the sea level distribution in order to estimate the frequencies of rare/high sea levels. The limit of 5 events/year was chosen because only the tail part of the distribution follows the exponential shape, not the entire distribution. In this way, the fit is also only done on sea level representing rare events, which may behave differently from the more frequent sea levels.</p> <p>Above mentioned explanations will be added to the manuscript as follows: "We extrapolated the ccdf with an exponential function fitted to the tail of the ccdf (Fig. 4). The exponential function was fitted to sea levels with a frequency of exceedance less than 5.7×10^{-4}, which corresponds to 5 hours/year. This limit was selected because only the tail part of the distribution follows the exponential shape, while more frequent sea levels behave differently."</p>
2. In Figure 4, the maximum frequency of exceedance occurs at the sea level of -50 cm, indicating that negative storm surges frequently occur in the study area. The reason for this should be explained in the paper.	<p>We explain in Chapter 2 (Components contributing to the sea surface level) that short-term sea level varies from -1.3 m to +2.0 m around the long-term mean sea level on the Finnish coast, and that these changes are mainly due to wind and air pressure variations. Thus -50 cm (in Figure 4) fits inside this range and is normal behaviour in the study area.</p>
3. In page 10-11, it is written: "The wave run-up can be calculated for different percentages, e.g. as the water level exceeded 2% of the time. We set out to seek a conservative estimate for the level exceeded once during the one hour time period." In the design of coastal defense structures, it is common to use the 2% run-up height to determine the crest freeboard. If the mean wave period is 8 s, the wave run-up	<p>We aim at estimating maximum total water level exceeded during one hour period. Thus we defined the wave run-up using the highest single wave during an hour, since this corresponds to one well defined event when the wave data and hourly water level data are combined statistically.</p> <p>See also our response to the comment [11] from Reviewer #2.</p>

<p>exceeding 2% run-up height occurs 9 times during one hour, whereas the run-up height exceeded only once during one hour is exceeded 0.22% of the time. Therefore, taking the run-up height exceeded once during the one hour time period is too conservative from the engineering point of view.</p>	
<p>4. In page 11, the relationship $H_{max} = 2H_s$ is used. Longuet-Higgins (1952, J. Marine Res. 11, 246-266) presented the relationship $H_{max} = 0.707\sqrt{\ln N}H_s$ for a storm with a relatively large number of waves N. Again, if the mean wave period is 8 s, the number of waves during one hour is 450, which gives $H_{max} = 1.75H_s$. Therefore, the relationship $H_{max} = 2H_s$ may be too conservative.</p>	<p>We used Longuet-Higgins (1952) to check our results. However, we didn't find that exact relationship in the paper, but interpolated the values of the Rayleigh distribution by using the values given in the Tables. The waves at the study sites are typically short. The mean zero-upcrossing period (T_z, calculated as T_{m02} from the spectral moments) is around 3 seconds (3.2 s at Länsikari and 2.8 s at Jätkäsaari). This means about 1200-1300 waves during an hour, which results in H_{max} being between 1.9H_s and 2H_s. We calculated this relation for the entire time series to provide an even better overview (see Figure RC_A).</p> <p>We agree that this was not presented properly in the manuscript. A more rigorous justification for choosing the relationship $H_{max}=2H_s$ will therefore be added.</p>
<p>5. The assumption of complete wave reflection from a coastal structure (i.e. $H_{runup} = H_{max}$) may also be a too conservative assumption. This assumption, however, could be justified if we take into account the effect of wave nonlinearity in shallow water (i.e. peaked crest and flat trough), which was not considered in this study.</p>	<p>The water at the study sites is relatively deep when considering the short waves generated by the local fetches (around 3 s at Länsikari). At Länsikari the depth is around 10 m and at Jätkäsaari it is around 13 m. Even for the longest waves the water depth is intermediate. Shallow water nonlinearities are therefore not expected to be significant.</p> <p>We want to stress that the study we cited with respect to the wave reflection was made exactly at the location of Jätkäsaari. It is therefore highly representative for this study. In Björkqvist et al. (2017) the short waves were damped by the wave damping chambers. However, the longer waves were fully reflected. Since the wave damping chambers only cover a short part of the shoreline, we have to consider conditions without the presence of them. We have no reason to believe, that all the waves wouldn't be fully reflected at a pure steep wall, since we have direct measurements of full reflection of waves that were too long for the wave damping chamber to be effective.</p>
<p>6. Sorensen (2006, Basic Coastal Engineering, 3rd ed., Springer, p. 237) presented the relationship $R_p = R_s\sqrt{\ln(1/p)/2}$ where R_p is the wave run-up height of</p>	<p>A lot of this has already been addressed, but in conclusion:</p>

<p>the exceedance probability p and R_s is the run-up height of the incident significant wave height as if it were a monochromatic wave. If we use $p = 0.02$ and $R_s = H_s$ (i.e. complete wave reflection), $H_{runup} = R_{2\%} = 1.4H_s$ which is 70% of the value used in this study. On the other hand, if we use $p = 0.0022$, which is the exceedance probability of the wave height exceeded only once during one hour (when the mean wave period is 8 s), $H_{runup} = R_{0.22\%} = 1.75H_s$. This changes to $H_{runup} = H_{max}$ (using the relationship $H_{max} = 0.707\sqrt{\ln N}H_s$), which is the same as the run-up height used in this study except that H_{max} is not calculated as $2H_s$ but as $1.75H_s$. In conclusion, to avoid too conservative estimate for wave run-up height, either $H_{runup} = 1.4H_s$ (general design standard) or $H_{runup} = 1.75H_s$ (run-up height exceeded once during one hour as taken in this study) should be used.</p>	<p>1) The choice of H_{max} instead of e.g. 2% exceedance value is not a matter of being conservative. It is a choice done to get the results to correspond to “one event”. It would be possible to choose a lower value that is exceeded e.g. 25 times. However, when combined with the sea level data the values would not be events, but “25 events”, and the probability of 0.4% would not correspond to one event in 250 years, but to 25 events in 250 years and would inevitably lead to some inference challenges.</p> <p>2) The relation $H_{max}=2*H_s$ is not really conservative assumption. It has its bases in the measurements and theory (Rayleigh distribution). This will be clarified in the manuscript also.</p> <p>3) The assumption of full reflection is the main conservative assumption. However, we feel it has a valid base, since we have observed fully reflected waves even when wave damping chambers are present. Since the damping chambers are not present everywhere, it is reasonable to assume that the short waves – that were damped by the chambers in the measurements – will be reflected in the same way as the longer waves. This might not be true, but since we have no evidence of the contrary, we feel that this is a valid assumption, albeit a conservative one.</p>
<p>7. In addition to Table 1, it may be worthwhile to show the curves of F_{SL} for 2017, 2050, and 2100.</p>	<p>The curve for the still water level in 2017 as well as for the years 2050 and 2100 at the Helsinki tide gauge are presented in Figure 8 in the manuscript.</p>
<p>8. Two-parameter Weibull distributions are used for the sensitivity analysis. It may be better to add the fitted Weibull distributions (along with the shape and scale parameters) in Figure 5 to show that the Weibull distribution fits well the observation.</p>	<p>See our response to comment [16] from #2 Reviewer.</p> <p>To provide a better comparison possibility between case study wave run-up distributions (Figure 5) and the theoretical wave run-up distributions, we plotted the theoretical wave run-up distributions also in a form of complementary cumulative distribution (see Figure RC_B) and this redrawn figure will be added to the manuscript.</p>
<p>Minor points</p>	
<p>1. 1st line below Eq. (1): wave height >> wave run-up height</p>	<p>This terminological mistake will be corrected to the text where the terms of equation (1) are explained i.e. “wave height” will be changed to “wave run-up”.</p> <p>See also our response to comment [12.2] from #2 Reviewer.</p>

Referee Comments #2

Comment	Authors response and changes in manuscript
<p>[1] The first comment is purely formal. Authors state in lines 22-23 (pag 3) that they are going to call “run-up level” to the combined water elevation (mean water level and wave run-up contributions). This is misleading since it is not the unusual approach in the literature. It should be better to use something like “total water level” to avoid confusion with the standard wave-induced run-up.</p>	<p>After re-consideration of the terms used in the manuscript we agree that using “run-up level” to represent the combination of still water level and wave run-up might be misleading and cause confusion with the wave related run-up. Thus, we will replace “run-up level” with “total water level” throughout the manuscript as suggested.</p>
<p>[2] <i>Lines 13-14 (pag 3)</i>. Coastal floods are also a consequence of storm-surges. Please rephrase the sentence.</p>	<p>We agree that coastal floods are also a consequence of storm surges and that the sentence is not properly formulated. As this sentence is not very relevant for our introduction (which is already quite long), we decided that the whole sentence will be removed from the manuscript.</p>
<p>[3] <i>Lines 6 (pag 4)</i>. In general terms, the wave-induced component of the water level at the shoreline is the run-up and not the wave height (a different thing is that you approach the run-up with the wave height but this depends on how you calculate it).</p>	<p>This terminological mistake will be corrected to the text where the terms of equation (1) are explained i.e. “wave height” will be changed to “wave run-up”.</p> <p>See also our response to your comment [12.2].</p>
<p>[4] <i>Line 1 (pag 5)</i>. Long-term mean sea level does not change from decade to decade. Mean sea level is continuously varying and “long-term” refers to the low-frequency component which, apparently, you consider to be associated to periods in the scale of decades (or longer).</p>	<p>We agree that the sentence was poorly formulated. However our purpose in the manuscript is to distinguish between the sea level variations taking place at short time scale (e.g. storm surges) and those that happen slowly within long time span (e.g. mean sea level change).</p> <p>The sentence will be reformulated in a following manner: “The long-term mean sea level on the Finnish coast, on decadal time scale, is affected by the global mean sea level, the post-glacial land uplift and the Baltic Sea water balance (Johansson et al., 2014).”</p>
<p>[5] <i>Section 3.1. Long-term sea level</i>. You are using long-term estimations of sea level at selected horizons based on a paper that is under review. If this component is important for your calculations, it can be difficult for some readers to trust on it without having access to the scientific work supporting used values.</p>	<p>The paper we are referring to has now been published. The reference list will be updated accordingly:</p> <p>Pellikka, H., Leijala, U., Johansson, M. M., Leinonen, K., Kahma, K. K., 2018. Future probabilities of coastal floods in Finland. <i>Continental Shelf Research</i>, 157, 32-42. DOI: 10.1016/j.csr.2018.02.006.</p>
<p>[6] <i>Section 3.2</i>. Please change the heading. Here you are not describing variability but just the existing data. They are simply water level measurements acquired by using tidal gauges. Use something similar</p>	<p>We agree that the heading was too complicated as the aim of this section is to just describe the tide gauge data. Thus we will change the heading of Section 3.2 simply to “Sea level data”.</p>

to heading of section 3.3 (e.g. tidal data, water level data).	
[7] <i>Lines 6-7 (Page 8)</i> . Please remove the last sentence “The significant wave height is ...”. If you want to use a definition of Hs use a formal one (e.g. based on spectral moments).	We will replace the formal definition given on page 8, line 4 with the one using spectral moments. The “layman” definition will also be removed as redundant, as you suggested.
[8] <i>Lines 23-25 (pag 8)</i> . See comment [1].	See our response to your comment [1].
[9] <i>Lines 10-11 (pag 9)</i> . When you explain which sea levels are used to obtain the probability distributions you mention that use sea levels with a given frequency (5 events/year or less in your case). This is equivalent to perform an extreme analysis in which you use a subset of your data composed by extreme events. Then, the usual way should be to select sea-level events by applying the POT method using a given threshold (which will result in a varying number of events per year that, in your case, is up to five events per year) and then fitting the obtained subset by a probability function (exponential in your case).	<p>In the POT method two limits are usually set. One is the threshold (e.g. a certain sea level value), which will give us a certain amount of events per year (on average). The second limit determines the distance between two points. This second limit is set to remove events that are not independent, which enables the final data set to converge to a Pareto distribution. The second limit can be in the order of 24-72 hours, but for sea level data in the Baltic Sea the correlation might be significantly longer (in the order of months). This is because the slow changes in the total water volume in the Baltic Sea.</p> <p>If a proper POT method is applied, the resulting distribution converges to a generalized Pareto distribution (GPD) and will no longer simply be the tail of the original distribution. The main point is the following: in order to use our method, we ultimately need to revert back to the full distribution, since the statistical combination with the wave run-up will otherwise not be possible. If we have fitted a GPD to the data we got by applying the POT method and use that tail to extrapolate the original data, then we are extrapolating the original distribution with a fit that has been made to a different distribution (the GPD). This is obviously something we want to avoid.</p> <p>By fitting the exponential distribution to the tail, we are essentially using the POT method to the extent it is possible in our case. Using the POT method “to its fullest” would change the distribution, since the entire point with the method is to converge the subset of the original data to a GPD. Since we are not only interested in the extreme values, but need the full distribution to combine the sea level data with the wave run-up, the traditional use of the POT method is not a suitable tool for our purposes.</p> <p>See also our response to comment [1] from #1 Reviewer.</p>

<p>[10] <i>Section 4.3.</i> You determine an attenuation factor for both coastal locations to derive local wave time-series from 15-year long offshore measurements. This is equivalent to derive an empiric wave propagation model instead of using a numerical model. However, your coastal wave time series are just 31 days long in Jätkäsaari and 11 days long in Länsikari (section 3.3). Given the short-time duration of these records, it is necessary to have more details on this analysis to trust on reconstructed long-term wave time series at both coastal sites. For instance, it should be great to have H_s coastal-H_s offshore plots at both locations under different conditions (T, θ) to see the expected uncertainty in the reconstruction.</p>	<p>First, we want to stress that the attenuated time series we get with the transfer function is not a valid realisation of the wave height time series for the entire 15 year period. The main idea is, that while we can get the typical values (although with a slight positive bias because the measurements were made in the autumn) directly from the measurements, we cannot get the rare exceedances. We therefore determined a transfer function that was adjusted to accurately model the highest values in the measurement time series. When used on the longer open sea wave buoy measurements we can then get information about the nearshore wave height during the more extreme wave events that have happened outside of our short measurement period.</p> <p>Figure RC_C shows that the estimated distribution from the transfer function coincides with the observed values at the tail of the observed distribution.</p> <p>We acknowledge that this is not an optimal way, but it was a practical solution to extract as much information from the existing data set as possible. However, the method presented in the paper is in no way reliant on the method we used to determine the wave height distribution.</p> <p>We will add the information shown in Figure RC_C also to the manuscript, in order to show in more detail how the wave run-up distributions were formed.</p>
<p>[11] <i>Line 1 (pag 11).</i> This is a complicated way to say that you use the maximum run-up, Ru_{max} instead of $Ru_{2\%}$.</p>	<p>Our purpose is to say that we use the maximum run-up and we acknowledge that our way of saying this could be more straightforward. We will rephrase the explanation as follows: "The final step was to estimate the wave run-up, i.e. the maximum vertical elevation of the water in relation to the still water level. We defined the wave run-up using the highest single wave during an hour, since this will produce one well defined event when combined statistically with the water level data." This sentence is followed by more detailed explanation of the selected method.</p>
<p>[12.1] <i>Line 3 (pag 11).</i> It should be great to include a typical coastal profile of the study sites (maybe after Fig 2) to see how steep they are, especially since you are using this characteristic to approach Ru by H.</p>	<p>We have added a picture of the shoreline at Jätkäsaari (Figure RC_D, from Björkqvist et al., 2017). Although this figure shows the wave damping chambers, the shoreline is similar at other locations</p>

	that are not equipped with wave damping chambers (see Figure 1 in Björkqvist et al., 2017).
[12.2] The concept of <i>run-up height</i> needs to be defined to avoid misunderstandings. The run-up height is usually defined as the vertical distance between highest run-up level R_u and deepest run-down R_d . However, when we simply use wave run-up we refer to the vertical distance with respect to the mean water level. Please, clarify what you are using.	We agree that concepts need to be clearly and uniformly defined throughout the paper. In this study we define the “run-up” as the maximum vertical elevation of the water in relation to the still water level during a certain period. We will define this clearly in the manuscript and remove “run-up height” definition to avoid misunderstandings.
[13] <i>Line 5 (pag 11)</i> . The use of the relationship $H_{max} = 2 H_s$ need to be justified. The ratio H_s/H_{max} can be quite variable depending on local conditions (see e.g. Oliveira et al. 2018, Ocean Engineering 153, 10-22). One possibility to select the value to be used is to obtain it from the wave data recorded at your offshore location.	We calculated this based on the wave data recorded at the nearshore location (not the offshore location, since the typical wave periods are much longer there). The mean zero-upcrossing period (T_z , calculated as T_{m02} from the spectral moments) are around 3 seconds (3.2 s at Länsikari and 2.8 s at Jätkäsaari). This means about 1200-1300 waves during an hour, which results in H_{max} being between $1.9H_s$ and $2H_s$ (Figure RC_A). See also our response to the fourth comment from Reviewer #1.
[14] The use of “full” reflection needs to be justified (or simply says that it is arbitrarily selected to be conservative). The study of Björkqvist et al (2017c) used to justify this selection was done in front of a Caisson breakwater. Since we do not know how the coast is (see comment [12.1]), it is difficult to see if the application of this reflection coefficient is appropriated for the site.	See our response to your comment [12.1].
[15] <i>Section 4.5</i> . Since you have 15 years of simultaneous data of water level and waves, why you did not convert these series into a single series of total water level (by simple summation) and then to obtain the probability distribution. This can give you a good estimation of the “real” joint probability distribution of water levels (for all components) under current conditions. This could be used to compare with the obtained one by combining individual probability functions.	This is an excellent point, which we would certainly have done if we had the data to do it. However, as addressed in point [10], the wave heights that are estimated do not produce a proper time series, but are used to complete the tail of the distribution based on the measurements (see Figure RC_C). Since the transfer function is constructed with the aim to get the highest tail (not to e.g. minimize the bias), it means that the lower wave heights are overestimated. This is acceptable, since they are not used to construct the distribution.
[16] <i>Section 5</i> . It is not clear which is the contribution of this analysis to overall results. If you are just using theoretical distributions, you do not need any data (?). However, for a real case (as it is yours) you should fit a probability distribution (Weibull in your	This is a relevant point. The purpose of the “sensitivity test” is to study how different wave height conditions (based on theoretical wave run-up distributions) affect the total water level when the still water level distribution is kept unchanged. We agree that the contribution of this section to the overall results is not clear, and calling it a “sensitivity

<p>case) and retain the best fit (with the corresponding Weibull parameters). Of course, if you change your Weibull parameters your results will change.</p> <p>You want to include here a sensitivity analysis but, there is no sensitivity analysis (nor uncertainty) associated to your previous selections (Ru formula (H), relationship between Hs and Hmax, refraction model, etc...). If you want to do a formal sensitivity analysis, probably you should account for the different contributions through the entire assessment.</p>	<p>test” is misleading. In order to clarify our aim of the analysis we will remove Section 5 and instead reorganize the “Results” section to include: 1) the case study at Helsinki, 2) the study with these theoretical wave distributions, and 3) a comparison between the results of these.</p>
<p>[17] Section 7.2. Lines 4-8 (pag 22). See comment [15].</p>	<p>See our response to your comment [15].</p>
<p>[18] Lines 9-20 (pag 22). This is true but this is also less and less common. As it is written, it seems that this is the most used approach. At present, flood assessments for combined water level-wave contributions, usually consider full time series instead of monthly maxima.</p>	<p>We acknowledge that we generalized unnecessarily the use of block maxima. We will rephrase the sentence: “Using block maxima of sea level variations — such as the monthly maxima used by Pellikka et al. (2018) — in our analysis would implicitly restrict the study of the joint effect to cases where the still water level is high, thus excluding combinations of moderate still water level and high waves.”</p>
<p>[19] Lines 21 to 25 (pag 22). More than the short-term variability in waves, probably, you must also consider the potential long-term variability in wave conditions for long time projections (see e.g. Méndez et al. 2006. Estimation of the long-term variability of extreme significant wave height using a time-dependent peak over threshold (pot) model." <i>JGR Oceans</i> 111,C7).</p>	<p>Using the verified wave model data from Björkqvist et al. (2018) we calculated the mean significant wave height at the GoF wave buoy for the years 1965-2005 (the hindcast cannot resolve the nearshore conditions of Länsikari and Jätkäsaari).</p> <p>The results are shown in Figure RC_E for both ice-free statistics and ice-included (as Hs=0) statistics. In both statistics the trend is small, and not statistically significant according to a t-test.</p> <p>This is supported by Kudryavtseva and Soomere (2017). The authors used satellite altimetry data (1996-2015) and found no statistically significant trend in the Gulf of Finland.</p> <p>Of course, the absence of evidence is not evidence of absence, but using the current knowledge we have no means to predict the future changes of the significant wave height in the GoF. We have mentioned using long-term scenarios for wave conditions in the Discussion part of the manuscript, as a potential improvement on our method in future studies.</p>

	<p>Méndez et al. (2006) used a POT-method where the coefficients of the GDP-distribution were allowed to vary in time. The time varying parameters can capture some of the seasonal variability that is lost if the POT-method is used on the entire data set with only one set of parameters. However, since the method implemented in this paper uses the full distributions, all seasonal variations are already present in the data, and no special methods are required to account for them.</p>
--	---

Referee Comments #3

Comment	Authors response and changes in manuscript
<p>1. As a general comment, the approaches taken for estimating the wave run-up are rather bold and general. There are definitely a number of not necessarily better but similarly justified choices and I wonder how big the uncertainty from making such choices might be relative to issues discussed in this text. My assumption would be that it is probably a major source for uncertainty. I suggest that this should at least be discussed and conclusions should be put into perspective.</p>	<p>You are correct that we have not justified our choices properly. Taking into account also the feedback from reviewers #2 and #1, there are three main points we need to address:</p> <ol style="list-style-type: none"> 1) Using the maximum wave as the run-up instead of a value exceeded e.g. 2% of the time. 2) The $H_{max}=2*H_s$ approximation. 3) The assumption of full reflection. <p>We will repeat our response to Reviewer #1 below:</p> <ol style="list-style-type: none"> 1) The choice of H_{max} instead of e.g. 2% exceedance value is not a matter of being conservative. It is a choice done to get the results to correspond to “one event”. It would be possible to choose a lower value that is exceeded e.g. 25 times. However, when combined with the sea level data the values would not be events, but “25 events”, and the probability of 0.4% would not correspond to one event in 250 years, but to 25 events in 250 years and would inevitably lead to some inference challenges. 2) The relation $H_{max}=2*H_s$ is not really a conservative assumption. It has its bases in the measurements and theory (Rayleigh distribution). This will be clarified in the manuscript also. 3) The assumption of full reflection is the main conservative assumption. However, we feel it has a valid base, since we have observed fully reflected waves even when wave damping chambers are present. Since the damping chambers are not

	<p>present everywhere, it is reasonable to assume that the short waves – that were damped by the chambers in the measurements – will be reflected in the same way as the longer waves. This might not be true, but since we have no evidence of the contrary, we feel that this is a valid assumption, albeit a conservative one.</p> <p>We will modify the manuscript to better explain the reasons for 1), better justify the validity of 2) and discuss the assumption taken to conclude 3).</p>
<p>2. I would appreciate if the authors could better motivate the sensitivity experiments described in section 5. I understand technically what was done but cannot see the added value. For the discussion of results and significance of differences, confidence intervals should be provided otherwise statements regarding the significance of the results such as on page 15, line 8 are difficult to assess.</p>	<p>See our response to comment [16] from #2 Reviewer.</p> <p>Our purpose is not to refer to statistical significance in the discussion of results and significance of differences, and we will modify our statements according to this in the “Results” section by e.g. replacing the term “significant” with more appropriate expression (e.g. “The contribution of the waves is now <i>larger compared to</i> the situation with the first pair.”)</p>
<p>3. Page 5, Lines 6-7: Contribution from rivers to the water balance in particular the seasonal or longer variability should be mentioned.</p>	<p>We will add a mentioning of the contribution of rivers to the water balance in Chapter 2 (in the section describing the long-term mean sea level).</p>
<p>4. Page 5, Line 19: There are higher waves reported for the North Sea in chapter 7 of “State and Evolution of the Baltic Sea, 1952-2005: A Detailed 50-Year Survey of Meteorology and Climate, Physics, Chemistry, Biology, and Marine Environment” (doi: 10.1002/9780470283134)</p>	<p>It is true that there are higher waves outside the Baltic Sea, which is a semi-enclosed basin and rather shallow compared to other seas around the globe. At this point we did not have an access to the referred book but as this paper focuses on the Baltic Sea we therefore in the text have referred to the highest wave that has been measured inside the Baltic Sea (see Björkqvist et al., 2017b).</p>
<p>5. Page 7, Lines 4, 5: Please use projections instead of predictions here and at several other places in the manuscript.</p>	<p>We agree that projections is better term for the mean sea level scenarios and this will be corrected throughout the manuscript as suggested.</p>
<p>6. Page 7, Figure 3 and Lines 1-3: Please explain a bit more detailed. I cannot immediately infer the numbers given in the text from the Figure. Please also mention the baseline; that is, the year relative to which changes were computed.</p>	<p>We agree that our explanation could be more detailed and clear.</p> <p>The purpose of Figure 3 is to show the different shapes of the mean sea level probability density functions for the selected years i.e. the spreading of the distribution towards the future. Figure 3 is drawn from the results of Pellikka et al. (2018) that is published now:</p>

	<p>Pellikka, H., Leijala, U., Johansson, M. M., Leinonen, K., Kahma, K. K., 2018. Future probabilities of coastal floods in Finland. <i>Continental Shelf Research</i>, 157, 32-42. DOI: 10.1016/j.csr.2018.02.006.</p> <p>To clarify our message, we have redrawn Figure 3 and rephrased its caption (see Figure RC_F) so that the numbers mentioned in the text can be read from the figure. The manuscript text will be changed accordingly, and the baseline will be also mentioned.</p>
<p>7. Figure 4: I would appreciate a comment on the extent to which the extrapolation is justified. The data seem to suggest an upper (physically based?) limit of about 150 cm.</p>	<p>We don't know of any physical upper limit for the short-term sea level variations. The value that seems to be the upper limit in Figure 4 (around 150 cm) is due to the fact that the highest observed points are not independent but originate from the same sea level event which lasted for several hours.</p> <p>We have addressed our decision to use the exponential fit by referring to studies of Särkkä et al., 2017 in the text.</p> <p>See also our response to the comment [1] from #1 Reviewer.</p>
<p>8. Page 12, Line 23: The authors introduce "SL-distribution" to refer to sea level variations but mainly use "still water levels" hereafter. This should be made consistent.</p>	<p>This is a good comment. We agree that "SL-distribution" is unnecessary definition and using it complicates the text. Thus we will rephrase the sentences that involve SL-distribution and used F_{SL} instead. The same procedure will be done for sentences including "SL,W-distribution" (i.e. SL,W-distribution will be replaced by $F_{SL,W}$).</p>
<p>9. Page 13, Table 1: Prediction should be replaced by projection. Confidence intervals would be helpful.</p>	<p>We will replace "prediction" with "projection" as suggested (see also our response to your comment [5]).</p> <p>We agree that confidence intervals would be helpful. However, calculating them would require more in depth analysis of the uncertainties of the sea level distributions (short and long-term), which we decided to leave outside this study where the main focus is to present the method for combining the sea level distributions with the wave distributions.</p>
<p>10. Section 8 "conclusions" is rather a summary of results.</p>	<p>We agree that the "Conclusions" section was mainly summarizing our results. Thus we will rewrite it to better address conclusions that arise from our results.</p>
<p>11. Page 23, Line 14: It could also be that none of them is eventually realized.</p>	<p>This is a good point and true. The sentence will be reformulated better.</p>

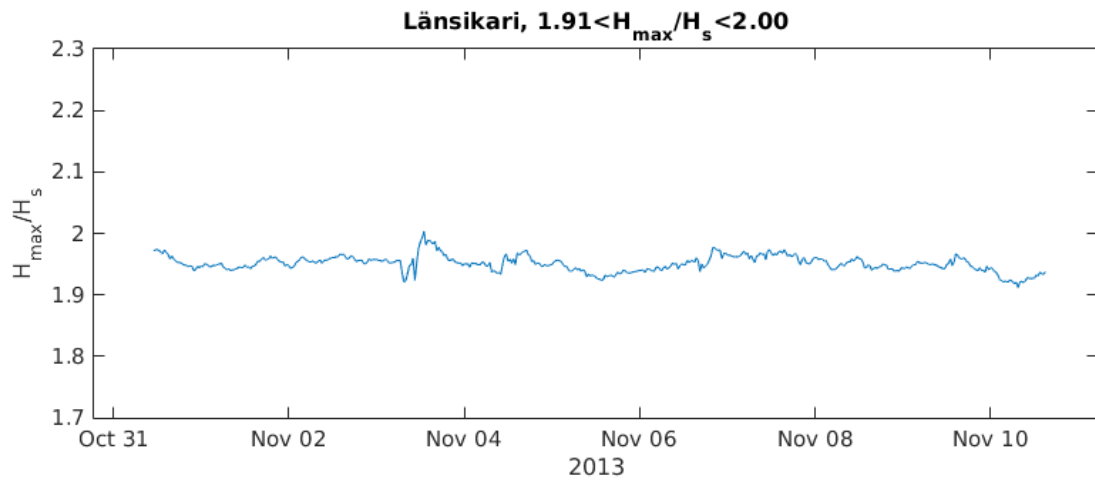
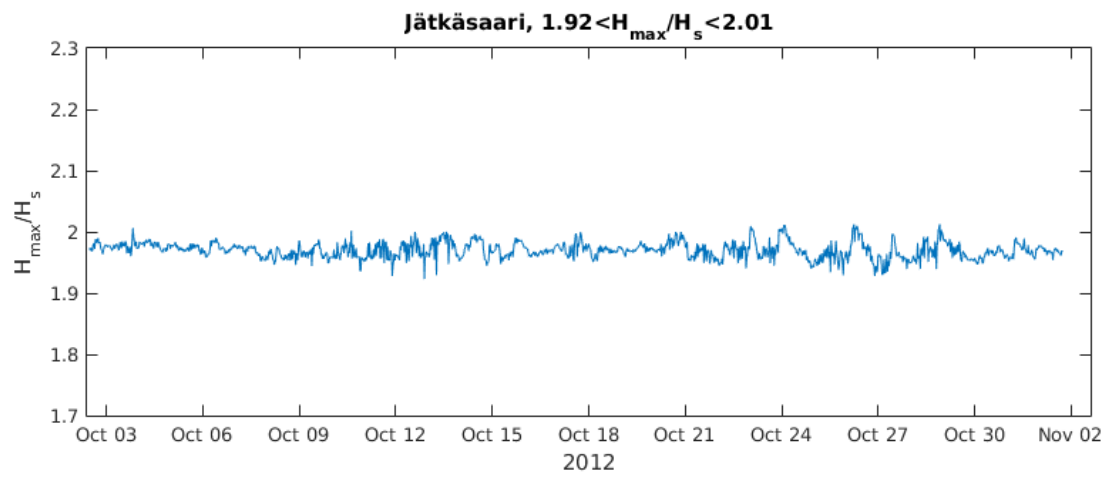

Figure RC_A. The ratio between the highest single wave and the significant wave height estimated from the Rayleigh distribution at Jätkäsaari and Länsikari.

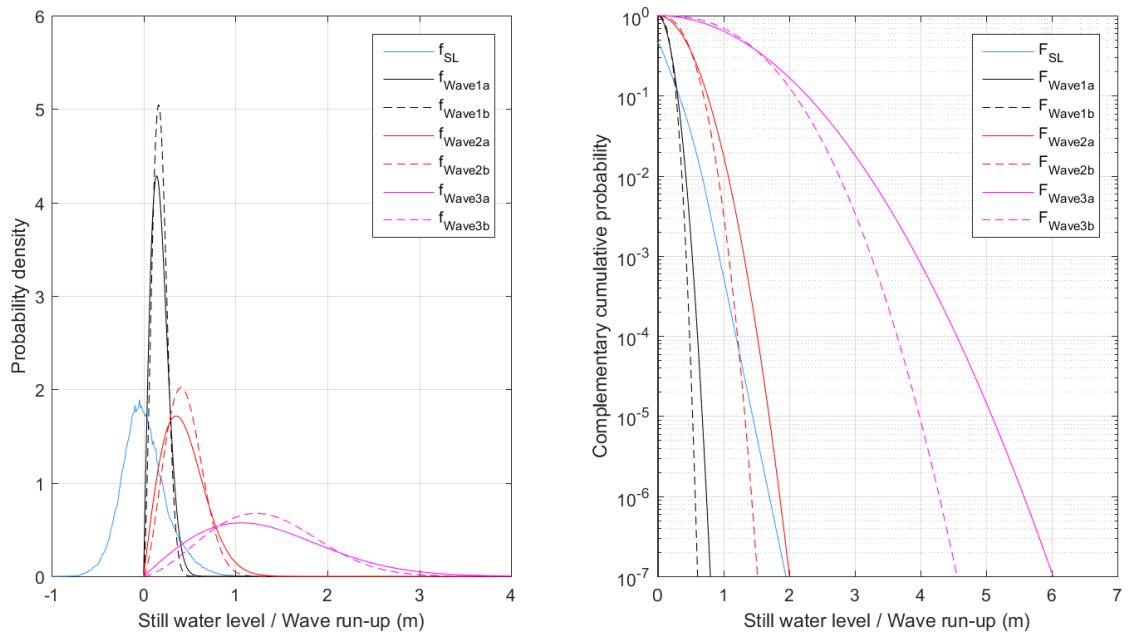

Figure RC_B. Pdfs (on the left) and cdfs (on the right) for the still water level and the six theoretical wave run-up distributions.

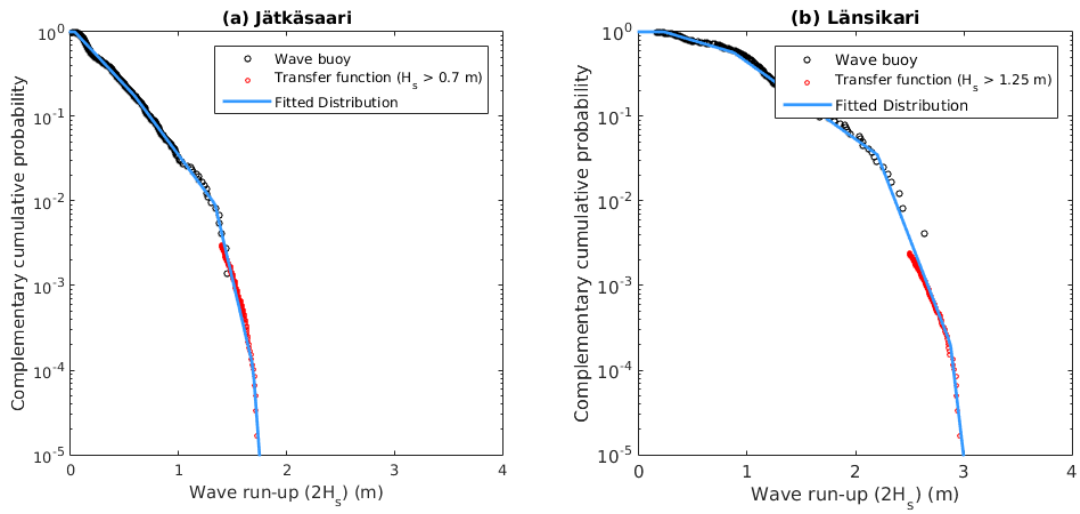

Figure RC_C. Wave run-up distributions for the two locations in the Helsinki archipelago: Jätkäsaari and Länsikari.

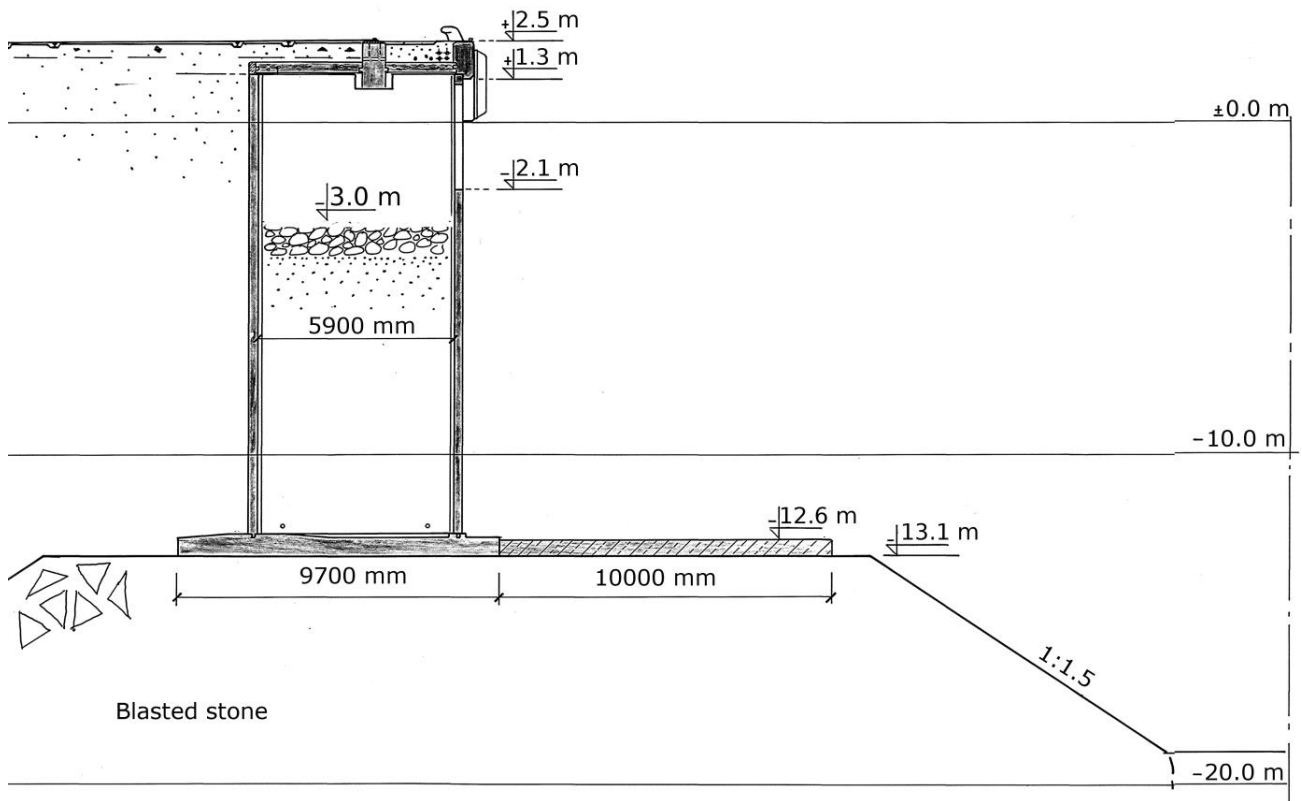

Figure RC_D. The shoreline at Jätkäsaari (from Björkqvist et al., 2017). Other parts of the shoreline are of similar shape (vertical walls), but are not equipped with wave damping chambers.

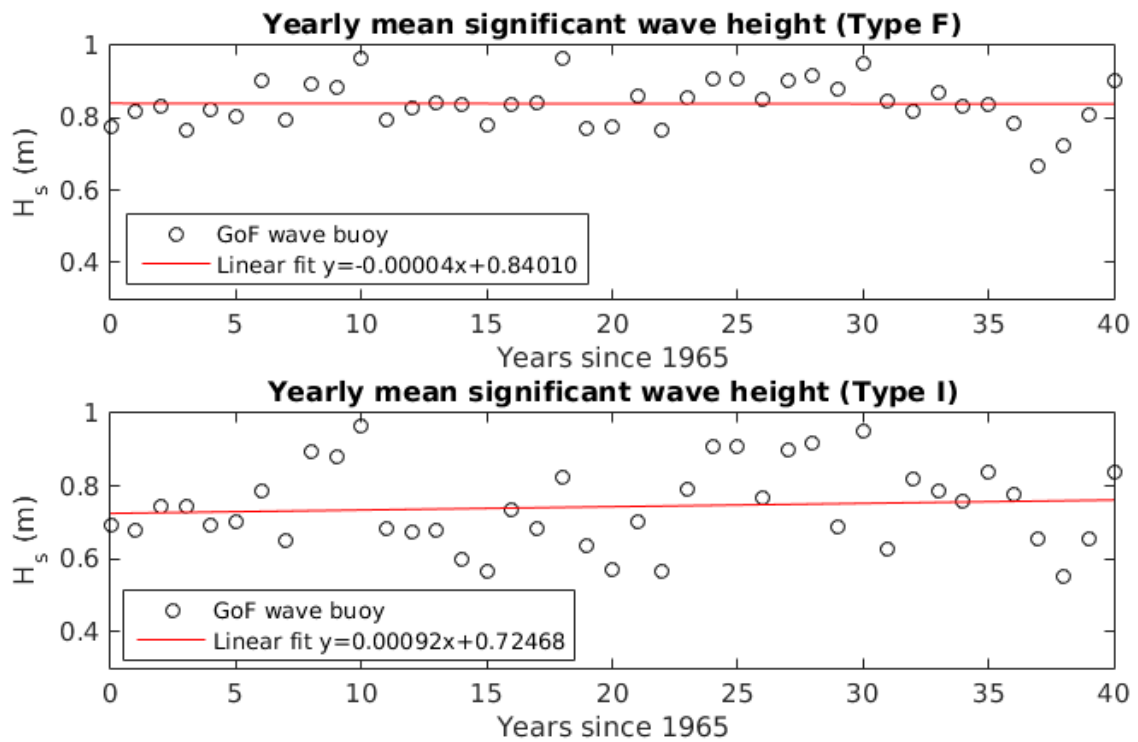

Figure RC_E. The yearly significant wave height at the Gulf of Finland wave buoy taken from the wave hindcast of Björkqvist et al. (2018). Trends were calculated for both the ice-free statistics and the ice-included statistics. Neither was statistically significant.

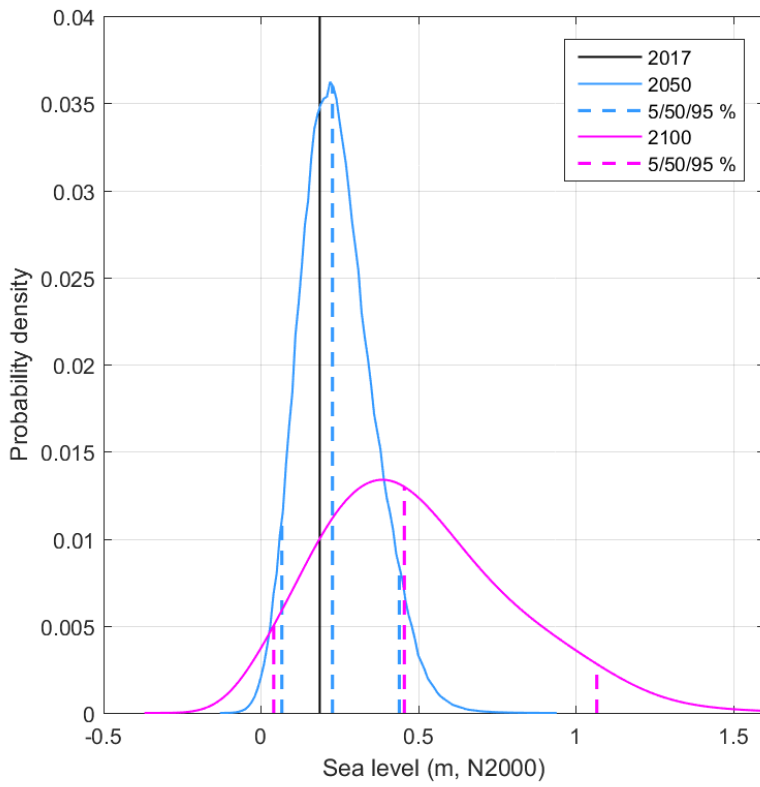

Figure RC_F. Probability density functions of future mean sea level at the Helsinki tide gauge for years 2050 and 2100 and the long-term mean sea level estimate of 0.19 m for year 2017. The 5th, 50th and 95th percentiles are shown for 2050 and 2100. The data in the Figure is from the results of Pellikka et al. (2018).

Combining probability distributions of sea level variations and wave run-up to evaluate coastal flooding risks

Ulpu Leijala, Jan-Victor Björkqvist, Milla M. Johansson, Havu Pellikka, Lauri Laakso, and Kimmo K. Kahma

Finnish Meteorological Institute, P.O. Box 503, FI-00101, Helsinki, Finland

Correspondence to: Ulpu Leijala (ulpu.leijala@fmi.fi)

Abstract. Tools for estimating probabilities of flooding hazards caused by the simultaneous effect of sea level and waves are needed for the secure planning of densely populated coastal areas that are strongly vulnerable to climate change. In this paper we present a method for combining location-specific probability distributions of three different components: 1) long-term mean sea level change, 2) short-term sea level variations, and 3) wind-generated waves. We apply the method in two locations in the Helsinki Archipelago to obtain run-up-total water level estimates representing the joint effect of the still water level and the wave run-up. ~~These estimates for the present, 2050 and 2100 are based on field measurements and mean sea level scenarios. In the case of our study locations, the significant locational~~ 2100. The variability of the wave conditions between the study sites leads to a difference in the safe building levels of up to one meter. The rising mean sea level in the Gulf of Finland and the uncertainty related to the associated scenarios contribute ~~significantly to the run-up notably to the total water~~ levels for the year 2100. ~~We also present a sensitivity test of the method and discuss its~~ A test with theoretical wave run-up distributions illustrates the effect of the relative magnitude of the sea level variations and wave conditions on the total water level. We also discuss our method's applicability to other coastal regions. ~~Our approach allows for the determining of different building levels based on the acceptable risks for various infrastructure, thus reducing building costs while maintaining necessary safety margins.~~

1 Introduction

Predicting coastal flooding and extreme sea level events has a focal role in designing of rapidly evolving coastal areas, that become continuously more populated and convoluted. Such flooding events, ~~related to extreme sea levels,~~ are influenced by long-term changes in mean sea level, together with short-term sea level variations and the wind-generated wave fields. These processes are further influenced by a variety of other processes and conditions like the vertical crustal movements, islands, the shape of the shoreline and the topography of the seabed. Because of a rising mean sea level, the effect of sea level variations accompanied by waves might cause more damage in the future than in the present conditions. In this study, we analyse the joint effect of the still water level and wind waves on the Finnish coast.

Globally, several studies have addressed the topic of combining sea level changes and variations with wind waves in different circumstances and locations, using different methods and assumptions. Hawkes et al. (2002) studied the combined effect of large waves and high still water in coastal areas of England and Wales using Monte Carlo simulations, accounting for the

dependence between the water level, the wave height and the wave steepness. Hawkes (2008) summarized joint probability methods and discussed issues related to data selection and event definition, concluding that the analysis method and source data should be well chosen to meet the requirements of a particular problem.

Wahl et al. (2012) applied Archimedean Copula functions in the German Bight to achieve exceedance probabilities for storm surges and wind waves. They found that using this methodology, realistic exceedance probabilities can be achieved and used to enhance the results from integrated (i.e. multivariate problems) flood risk analyses. A copula based approach was also implemented by Masina et al. (2015) to examine the joint distribution of sea level and waves at a location suffering from coastal flooding in the northern Italy (Ravenna coast). This method accounts for the dependence structure between the variables, and the authors also assessed the present probability of marine inundation accounting for the interrelationship among the main sea condition variables and their seasonal variability. Results of this study highlight the need to utilize all variables and their dependences simultaneously for obtaining realistic estimates for flooding probabilities.

In a study conducted by Prime et al. (2016), the authors used a combination of a storm impact model and a flood inundation model to quantify the uncertainty in flood depth and extent of a 0.5% probability event in the Dungeness and Romney Marsh coastal zone in the UK. They found that the most significant flood hazards on their study site were caused by low swell waves during highest water levels, as opposed to large wind waves occurring at lower water levels. Chini and Stansby (2012) used an integrated modelling system to investigate the joint probability of extreme wave height and water level at Walcott on the eastern coast of the UK, thus determining changes in overtopping rates. Using different scenarios for the mean sea level rise, the authors found that flooding probabilities are mainly influenced by changes in water level, as opposed to changes in the waves conditions. Cannaby et al. (2016) reached a similar conclusion when studying coastal flooding risks in the Singapore region.

Although the changes in water level have been deemed to have ~~to~~ the highest impact on flooding risks by several authors, Chini et al. (2010) found the near-shore wave conditions in the East Anglia coast (UK) to be sensitive to the changes in water level. The authors used five linear sea level rise scenarios, and one climatic scenario for storm surges and offshore waves to study the waves between 1960 and 2099. Cheon and Suh (2016) also found that the depth-limitation of waves can be relaxed with increasing mean sea level, thus leading to increased risks for wave-induced damages on inclined coastal structures.

The Baltic Sea is a shallow semi-enclosed marginal sea, connected to the Atlantic Ocean only through the narrow and shallow Danish Straits. This gives the sea level variations in the Baltic Sea an unique nature, which differs from that on the ocean coasts. The components of local sea level variations in a short time scale include wind waves, wind and air pressure induced sea level variations, currents, tides, internal oscillation (seiche) and meteotsunamis. Long-term changes are related to the climate change driven mean sea level variations, postglacial land-uplift, and the limited exchange of water through the Danish straits, which causes variations up to 1.3 m in the average level of the Baltic Sea on a weekly time scale (Leppäranta and Myrberg, 2009; Pellikka et al., 2014; Johansson et al., 2014).

Both sea level and wind waves have been studied thoroughly separately in the Baltic Sea area, but research into their joint effect is sparse compared to coastal regions outside ~~of~~ the Baltic Sea. Hanson and Larson (2008) examined jointly waves and water levels to estimate run-up levels (as the sum of the mean water level and the wave run-up height) on the Swedish coast

in the southern Baltic Sea. They established probability distributions based on existing climate data (mainly wind and water level data) including also scenarios of future climate change. ~~The~~ On the Estonian coast in the Gulf of Finland the impact of breaking waves on the mean water level (wave set-up) ~~has been studied on the Estonian coast in the Gulf of Finland. Based~~ was studied by Soomere et al. (2013) who found, based on results from a numerical wave model, ~~Soomere et al. (2013) found~~ the wave set-up to be strongly affected by the wind direction. Pindsoo and Soomere (2015) reached the same conclusion in a study that also accounted for varying offshore water level variations simulated by the Rossby Centre Ocean (RCO) model.

In Finland, there is a clear demand for flooding risk evaluation. The irregular coastline ~~of approx. 46 000 km~~ is characterised by coastal archipelagos consisting of about 73 000 islands. Especially the southern part of the coast ~~might will likely~~ become exposed to increasing flooding risks, ~~since its rather small land uplift rate will no longer cancel out the accelerating mean as~~ the land uplift rate no longer compensates for the accelerating sea level rise (~~Pellikka et al., 2017~~)(Pellikka et al., 2018).

~~The previous sea level records at almost all of the tide gauges along the Gulf of Finland were exceeded in~~ During the record-breaking storm Gudrun in 2005 ~~during the storm Gudrun. In that flooding event~~, three different components acted simultaneously in the Gulf of Finland: a high total water amount in the Baltic Sea, a high phase of the standing waves (seiches), and severe winds piling up the water and waves towards the shore. Gudrun caused major damage to coastal infrastructure on both north and south sides of the Gulf of Finland (Parjanne and Huokuna, 2014; Tönisson et al., 2008; Suursaar et al., 2006). ~~The coastal floods, especially in the Gulf of Finland, seem to be the most severe hazard among the extreme sea events (storm surges etc.) in the Baltic region (Kulikov and Medvedev, 2013).~~

The earlier flooding risk estimates in Finland (~~Kahma et al., 1998, 2014~~), ~~Pellikka et al., 2017~~ (Kahma et al., 1998, 2014; Pellikka et al., based on combining the probability distributions of the observed short-term sea level variability and the long-term mean sea level projections (Johansson et al., 2014). On top of these estimates ~~for the sea level variations up to 2100~~, a location-specific additional height for wind waves (henceforth "wave action height") was accounted for separately.

In this study, we ~~use a probabilistic method to calculate the joint effect of the above mentioned two components of sea level, and wind waves. We~~ utilize location-specific probability distributions of water level and wave run-up (~~the maximum vertical elevation of the water in relation to the still water level during a certain period~~). ~~We aim at getting to obtain~~ a single probability distribution for the maximum absolute elevation of the continuous water mass (Fig. 1). For simplicity, we call this resulting elevation the run-up total water level. The method presented in this paper has been applied to assess the safe building heights on the coast of Helsinki (Kahma et al., 2016).

This paper is structured in the following manner. In Sect. 2, we outline the parameters affecting the sea surface level on the Finnish coast. In Sect. 3, we introduce the scenarios and observations used in this study. This is continued in Sect. 4 by forming the sea level and wave probability distributions, presenting the theory for evaluating the sum of two random variables, and the particulars of applying it to sea level variations and wind waves. ~~We then investigate the sensitivity of the approach on the properties of the probability distributions by applying it to different theoretical wave distributions with known parameters in Sect. ??.~~ ~~We~~ In Sect. 5 we apply the method on a case study in the Helsinki Archipelago ~~in Sect. 5 and beside it investigate theoretically how different wave height conditions affect the resulting total water level~~. The paper is finished by discussion on the relevance and applicability of the results in Sect. 6, and finally conclusions in Sect. 7.

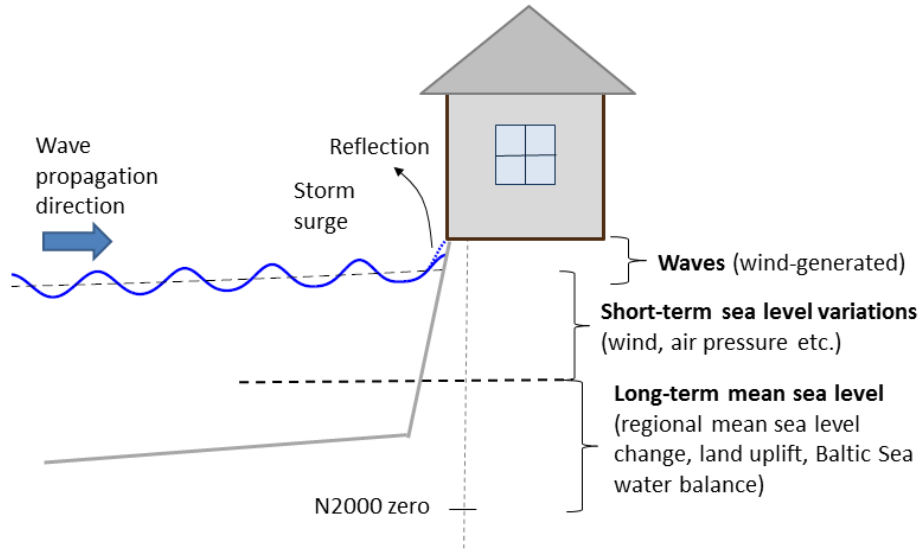

Figure 1. The run-up-total water level i.e. the maximum absolute elevation of the continuous water mass (solid blue) is a result of the 1) long-term mean sea level change, 2) short-term sea level variations and 3) wind-generated waves. On a steep shore the waves can also be fully or partially reflected (dotted blue).

2 Components contributing to the sea surface level

The instantaneous sea surface height at any coastal site in the Baltic Sea is affected by several physical processes in different time scales. In this study, we present the local sea surface height or, more precisely, the elevation to which the use the term still water level to represent the maximum elevation of the water level (incl. short- and long-term sea level variations). Moreover,

5 we use the term total water level H to represent the maximum absolute elevation of continuous water mass reaches, H , as a sum of three components with different time scales (Fig. 1):

$$H = S_L + S_S + H_{runup} \quad (1)$$

where S_L stands for the long-term sea level, S_S for the short-term sea level variations, and H_{runup} for the wave height run-up above the still water level ($S_L + S_S$). ~~For clarity, we use the order: 1) long-term sea level, 2) short-term sea level, 3) waves throughout the paper.~~

The long-term mean sea level ~~changes slowly from decade to decade. On~~ on the Finnish coast ~~it~~, on decadal time scale, is affected by the global mean sea level, the post-glacial land uplift and the Baltic Sea water balance (Johansson et al., 2014). The global mean sea level is rising due to thermal expansion ~~and the melting of e.g. the Antarctic and the Greenland of sea water and melting of glaciers and~~ ice sheets. Nevertheless, the rising sea level is locally mitigated by the post-glacial land uplift, which presently amounts to 3–10 mm/yr on the Finnish coast. The mean sea level in the Baltic Sea can also deviate from the mean ocean level because of the limited water exchange through the narrow and shallow Danish Straits, which connect the Baltic Sea to the North-Atlantic Ocean. ~~The Baltic Sea water balance is mainly controlled by the in- and outflow of water through the Danish Straits are mainly driven by the regional~~ wind and air pressure conditions ~~over~~, while other factors such as river runoff, evaporation and precipitation have a negligible effect on the Baltic Sea ~~and North-Sea areas~~ water balance.

Short-term water sea level variations on sub-decadal time scale on the Finnish coast range from -1.3 m to +2.0 m above the long-term mean sea level, with time scales ranging from year-to-year variability of the Baltic Sea total water volume down to storm surges and other rapid variations in less than an hour. The week-to-week variability of the water volume results into a sea level variability of about 1.3 m, while the shorter-period internal variations in the Baltic Sea basin contribute several tens of centimetres to the sea level variability (Leppäranta and Myrberg, 2009). Along the Finnish coast, the largest variations occur near the closed ends of the Bay of Bothnia and Gulf of Finland, while the range of variability on sites closer to the central area of the Baltic Sea is substantially smaller (e.g. Johansson et al., 2001). These variations are mainly driven by wind and air pressure variations. Ice conditions in the winter also affect the water level variability, but unlike in many other coastal areas, the tidal variations ~~are only a few centimeters range only up~~ to 10–15 centimeters on the Finnish coast (Witting, 1911; Leppäranta and Myrberg, 2009; Särkkä et al., 2017).

The wave conditions in the Baltic Sea are influenced by the limited fetch, the topography of the seabed and the seasonal ice-cover (Tuomi et al., 2011). The highest observed significant wave height in the Baltic Sea is 8.2 m (Björkqvist et al., 2017b). In the Gulf of Finland the growth of the waves is restricted by the narrowness of the gulf (Kahma and Pettersson, 1994), but a significant wave height of 5.2 m has still been measured in the centre of the Gulf of Finland (Pettersson et al., 2013). Close to the shoreline the waves are modified by the archipelago and the irregular shoreline (Tuomi et al., 2014; Björkqvist et al., 2017a). The significant wave height close to the coast in the Helsinki archipelago has been estimated to not exceed 2 m (Kahma et al., 2016), but the steep shoreline near Helsinki causes wave reflection leading to a positive interference (Björkqvist et al., 2017c). This ~~wave~~-reflection affects the ~~value of the~~ wave run-up, which is the vertical elevation ~~during a certain time (where the continuous water mass reaches~~ with respect to the still water level).

3 Scenarios and observations used in this study

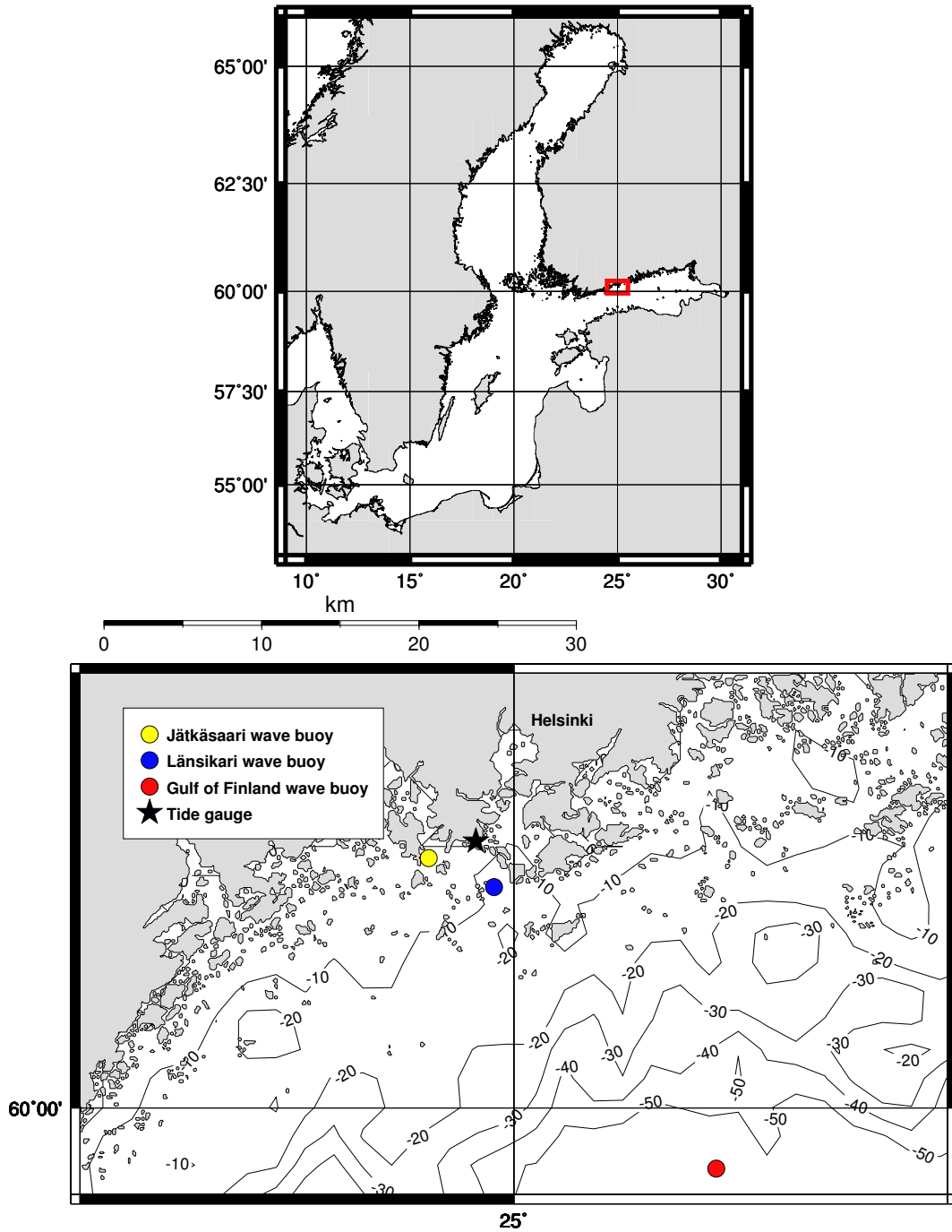

Figure 2. The coastal area off Helsinki and the measurement sites used in the study. The red box in the Baltic Sea map (top) marks the area shown on the bottom. The circles mark the location of the moored wave buoys and the star represents the Helsinki tide gauge used to collect the sea level data. The contours mark the approximate water depth.

~~To estimate the three components contributing to the coastal sea surface height (Eq. 1) in the present conditions and in the future, we used a combination of literature-based scenarios and observations.~~

3.1 Long-term mean sea level: past estimate and future scenarios

We focused our calculations on three different ~~time instants: the present year~~ years: 2017, ~~and future years~~ 2050, and 2100.
5 ~~Pellikka et al., 2017~~ [Pellikka et al. \(2018\)](#) calculated estimates for the past long-term mean sea level, as well as future scenarios, on the Finnish coast. They estimated the past and present long-term mean sea level as a combination of the past actualised global sea level rise, land uplift, and the Baltic Sea water balance. The significant year-to-year variability in the Baltic Sea water balance was smoothed out by a 15-year floating average.

The future scenarios of ~~Pellikka et al., 2017~~ [Pellikka et al. \(2018\)](#) were based on an ensemble of 14 global mean sea level
10 rise ~~predictions~~ [projections](#) from the recent scientific literature. Each ~~prediction~~ [projection](#) was adjusted to the Finnish coast by taking into account the uneven geographical distribution of the thermal expansion of sea water, ocean dynamical changes, and the fingerprints of the melting ice masses. The regionalized ~~predictions~~ [projections](#), along with their uncertainties, were combined to obtain a probability distribution of ~~future~~ [the](#) sea level rise in 2000–2100. Lastly, these localized sea level rise scenarios were combined with the postglacial land uplift and an estimate of wind-induced changes in the Baltic Sea water
15 balance. For more details of the method, see Johansson et al. (2014) and ~~Pellikka et al., 2017~~ [Pellikka et al. \(2018\)](#). In Helsinki, the change in mean sea level in 2000–2100 was ~~predicted~~ [projected](#) to be 30 cm (–15 cm . . . 87 cm, 5–95% uncertainty range).

3.2 ~~Observed short-term sea~~ [Sea level variability](#) [data](#)

The Finnish Meteorological Institute (FMI) operates 14 tide gauges along the Finnish coast, most of which have been operating since the 1920s. We used ~~sea level observations from the Helsinki tide gauge, which started operation in 1904. Hourly sea level~~
20 ~~observations from Helsinki are available in digital format since 1971, providing a continuous 46 year~~ years (1971–2016) [data set](#) of instantaneous hourly sea level ~~values~~ [observations from the Helsinki tide gauge](#). The Finnish sea level data are measured in relation to a tide gauge specific fixed reference level, which is regularly levelled to the height system N2000. The height system N2000 is a Finnish realization of the common European height system. The N2000 datum is derived from the NAP (Normaal Amsterdams Peil, Saaranen et al., 2009). For a more detailed description of the tide gauge data, measurement
25 techniques and quality, see Johansson et al. (2001).

The sea level variations are location-specific, but as our study area is limited to sites less than 5 km away from the Helsinki tide gauge, we considered the sea level variability measured at the tide gauge sufficiently representative for both study sites at Jätkäsaari and Länsikari (Fig. 2).

3.3 Wind wave data

30 FMI conducts operational wind wave measurements in four locations in the Baltic Sea. In the Gulf of Finland, the observations are carried out using a Datawell Directional Waverider moored in the centre of the gulf (see Fig. 2). However, these open

sea observations are not representative of nearshore wave conditions (e.g. Kahma et al., 2016; Björkqvist et al., 2017a). The operational measurements have therefore been ~~supported~~ supplemented by short-term observations with smaller Datawell G4 wave buoys inside the Helsinki archipelago.

We used the open sea measurements from the operational Gulf of Finland wave buoy in 2000–2014 in combination with
 5 shorter time series at chosen locations inside the Helsinki coastal archipelago. The measurements in the archipelago were conducted at Jätkäsaari (31 days in October 2012) and Länsikari (11 days in November 2013) (see Fig. 2). These shorter measurements were a part of a research project commissioned by the City of Helsinki (Kahma et al., 2016).

We chose the measurement sites at Jätkäsaari and Länsikari so that they would represent two different kinds of wave conditions: Jätkäsaari is close to the shore, in a place well sheltered from the open sea by islands. Länsikari, on the other hand, is
 10 located in the outer archipelago, relatively unsheltered from the open sea conditions.

~~We determined the significant wave height H_s from the 26 minute wave buoy time series as $H_s = 4\sqrt{\sigma^2}$, where σ^2~~ Most wave parameters can be defined using spectral moments

$$m_n = \int f^n S(f) df, \quad (2)$$

where $S(f)$ is the variance density spectrum (m^2Hz^{-1}) given as a function of the wave buoy's vertical displacement frequency.

15 The significant wave height ~~is a statistical parameter representing the height of the waves during a certain time or area, and it approximately corresponds to the wave height estimated by an experienced mariner.~~ can then be calculated as

$$H_s = H_{m0} = 4\sqrt{m_0}. \quad (3)$$

The wave period T_{m02} is defined as

$$T_{m02} = \sqrt{\frac{m_0}{m_2}}. \quad (4)$$

20 4 Probability methods to combine sea level variations and wind waves

As a first step in estimating the combined effect of the long-term mean sea level, the short-term sea level variability, and the wind waves on the frequencies of exceedance of coastal floods, we constructed probability distributions for each of them separately (Sect. 4.1–4.3). Next, we calculated the probability distributions of their sum: the method for this is presented in Sect. 4.4, and applied on the three constructed distributions in Sect. 4.5.

In this paper, we use three types of probability distributions. The probability density function (pdf) f_x , the cumulative distribution function (cdf) F_x , and the complementary cumulative distribution function (ccdf) \bar{F}_x of the random variable x are defined as:

$$\begin{aligned} f_x(x) &= P(x = x) \\ F_x(x) &= P(x \leq x) \\ \bar{F}_x(x) &= P(x > x) = 1 - F_x(x) \end{aligned} \tag{5}$$

- 5 Since our data is based on hourly values, we ~~calculated~~ converted the frequencies of exceedance from the ccdf ~~by multiplying the probabilities by to events/year by multiplying them with~~ the average number of hours per year (8766). By using hourly sea level values we practically assume a constant sea level for the entire hour. When summing a one hour constant sea level value with a one hour maximum wave run-up ~~elevation~~ with respect to the mean water level, the result is the maximum absolute elevation within one hour. This maximum absolute elevation during one hour is defined as one event.
- 10 ~~We use the term still water level to represent the maximum elevation of the water level (incl. short- and long-term sea level variations) corresponding to a certain frequency of exceedance. Moreover, we use the term run-up level to represent the maximum elevation of continuous water mass caused by the joint effect of sea level and waves corresponding to a certain frequency of exceedance.~~

4.1 Distributions of the long-term sea level scenario

- 15 The probability distributions for the long-term mean sea level scenarios on the Finnish coast were calculated by ~~Pellikka et al., 2017~~ Pellikka. We used their pdfs for sea level scenarios at Helsinki in 2050 and 2100, and the long-term mean sea level estimate of 0.19 m for year 2017 in reference to the N2000 height system (Fig. 3). The medians of these scenarios ~~predict~~ project a rise of ~~4 cm~~ 0.04 m from the estimated mean sea level of 2017 ~~(+19 cm)~~ up to 2050, and a rise of ~~28 cm~~ 0.27 m from 2017 to 2100. The uncertainties, however, increase markedly in the future, the width of the 5% to 95% range of the cdf being ~~37 cm~~ 0.37 m in
- 20 2050 and ~~103 cm~~ 1.03 m in 2100.

4.2 ~~Distributions~~ Distribution of the short-term sea level variability

- We constructed the probability distribution of short-term sea level variability from the observed sea levels in 1971-2016. The observed sea levels ~~, from which the wave action has been filtered out,~~ practically represent the sum of the two first terms of Eq. 1. We subtracted the annual values of the past long-term variations (S_L ; see Sect. 3.1) from the observed time series, to
- 25 obtain the short-term variability S_S .

We then calculated the ccdf for the short-term sea level variations. ~~We extrapolated the ccdf to frequencies of exceedance smaller than 1/46 years, and extrapolated it~~ with an exponential function ~~fitted to the tail of the ccdf~~ (Fig. 4). The exponential function was fitted to the tail of the ccdf, to sea levels with a frequency of exceedance ~~of less than 5.7×10^{-4} , which corresponds to 5 events~~ hours/year or less. This limit was selected because only the tail part of the distribution follows the exponential

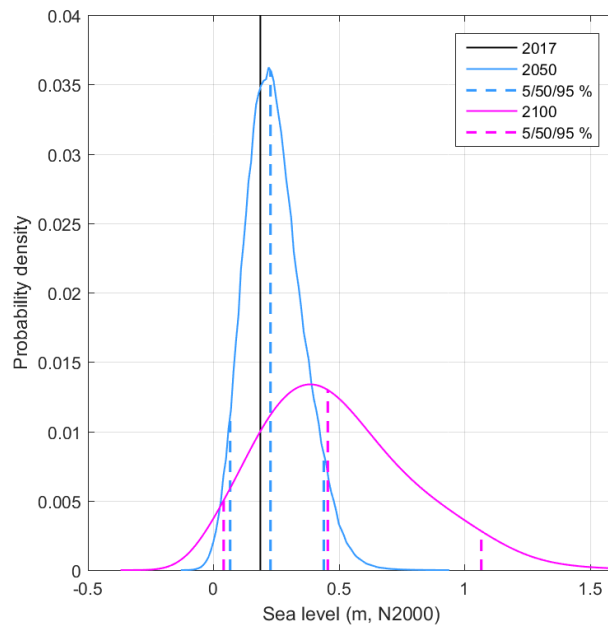

Figure 3. Probability density functions of future mean sea level at the Helsinki tide gauge for years 2050 and 2100 ~~and the long-term mean sea level estimate of 0.19 m for year 2017.~~ and the long-term mean sea level estimate of 0.19 m for year 2017. The 5th, 50th and 95th percentiles are shown for 2050 and 2100. The data in the Figure is from ~~Pellikka et al., 2017~~ the results of Pellikka et al. (2018).

shape, while more frequent sea levels behave differently. Särkkä et al. (2017) examined different functions and methods for extrapolating sea level cdfs at Helsinki. They found that both a Weibull and an exponential extrapolation of simulated daily sea level maxima produced results well in line with a Generalized Extreme Value (GEV) fit to ~~annual-simulated-simulated~~ annual-simulated-simulated sea level maxima.

5 4.3 Distributions of the wind wave run-up

4.3.1 Observed distributions

The short time series measured at Jätkäsaari and Länsikari (Sect. 3.3) are not long enough for constructing the local wave height probability distributions. We therefore compared these measurements to the simultaneous open sea data from the Gulf of Finland to determine an attenuation factor for each wave direction and wave period. The attenuation factors were then
 10 applied to the 15-year open sea measurement record to produce estimates of the wave conditions at the study locations. We calculated hourly significant wave heights from two consecutive measured 30-minute values, to be able to combine these with the hourly sea level data.

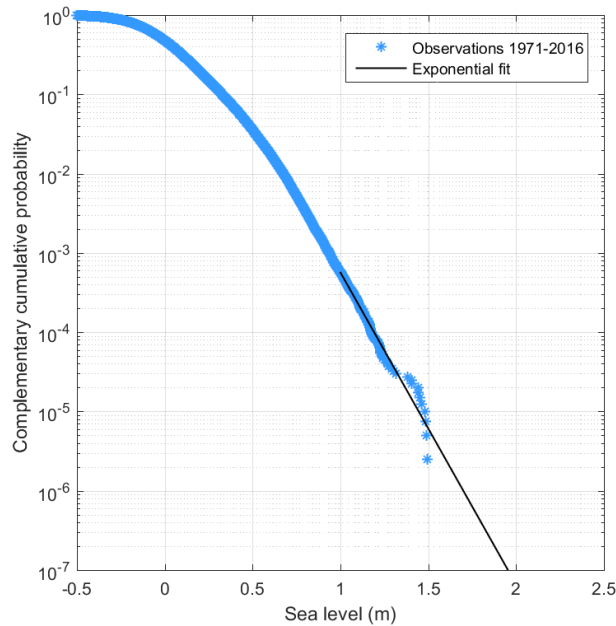

Figure 4. Ccdf of the short-term sea level variations at the Helsinki tide gauge: observed hourly values in 1971–2016, from which a time-dependent estimate for the long-term mean sea level has been subtracted.

The wave height values obtained by attenuating the open sea data were combined with the local measurements, and ccdfs were estimated by fitting piecewise exponential functions to the data. For the large values of the cdf the exponential function was fitted to the observational data, while for the smaller values (rarer events) a fit was made to the modelled values. These two pieces were connected to form one continuous distribution (see Fig. 6). The distribution was then extrapolated using an exponential fit. Since neither the observations nor the modelled values are by themselves sufficient to form a probability distribution, the above method was chosen to make the most efficient use of both data sets.

The final step was to estimate the wave run-up, i.e. the maximum vertical elevation of the water in relation to the still water level during a certain period, which in our case was an hour. The wave run-up can be calculated for different percentages, e.g. as the water level exceeded 2% of the time. We set out to seek a conservative estimate for the level exceeded once during the one hour time period using the highest single wave during an hour, since this will produce one well defined event when combined statistically with the water level data.

The highest wave during an hour was determined by assuming that the height of the single waves are Rayleigh distributed, following Longuet-Higgins (1952). At both study sites the relation $1.9H_s < H_{max} < 2.0H_s$ was valid for the entire measurement period of the wave buoys. For simplicity we will use $H_{max} = 2H_s$ throughout the paper. The high coefficient is explained by the waves being short inside the archipelago (mean values for T_{m02} were 3.2 s for Länsikari and 3 s for Jätkäsaari).

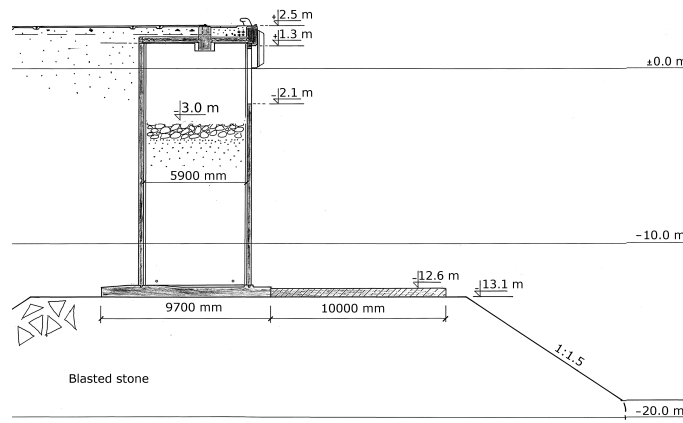

Figure 5. Wave run-up distributions for the two locations in The shoreline near the Helsinki archipelago: Länsikari and Jätkä. Jätkäsaari wave buoy. A part of the shoreline is equipped with wave damping chambers. Reprinted from Björkqvist et al. (2017c).

The run-up height depends on a number of parameters, but on a steep, sufficiently deep shoreline, the maximum vertical elevation is determined by the highest single individual wave, which is further magnified by reflection. As a simplification, we transformed Spectral wave measurements have been conducted at the Jätkäsaari study site (Björkqvist et al., 2017c) in front of a wave damping chamber (Fig. 5). The authors found a reflection coefficient of 1.5 for the significant wave height H_s , to the maximum single wave, H_{max} , by a multiplication by two. This is an upper limit compared to the widely used Rayleigh distributions and empirical distributions (Forristal, 1978). We also assumed that the highest single wave is completely reflected, which is a conservative estimate based on direct measurements of reflected waves at a steep coastal construction (Björkqvist et al., 2017c); this resulted in another multiplication of H_{max} by two to get the maximum reflected wave height. Finally, the height of the crest of such wave when the measurements were compared to the wave buoy measurements, since the shorter waves were damped by the chambers. However, the longest waves were fully reflected.

Our results should be valid also for the part of the shoreline that is not equipped with wave damping chambers. Based on the results of Björkqvist et al. (2017c) it is necessary to assume that the shorter waves would be fully reflected in a similar manner as the longer waves if no damping devices are present. We therefore used the conservative assumption of full reflection, thus doubling the single highest wave at the shore ($H_{max,refl} = 4H_s$), but since only half of the wave is above the still water level is half of the wave height, which is defined from trough to crest. Thus, we arrive at the expression $H_{runup} = 2H_s$. Shallow water wave non-linearities are ignored, since the wave lengths are typically small relative to the water depth at the shore. The resulting cumulative wave run-up distributions are illustrated in Fig. 6.

4.3.2 Theoretical distributions

One traditional distribution used to describe the significant wave height at a certain location is the Weibull distribution (Battjes, 1972). Nevertheless, the wave conditions at the study locations in this paper are heavily influenced by e.g. the

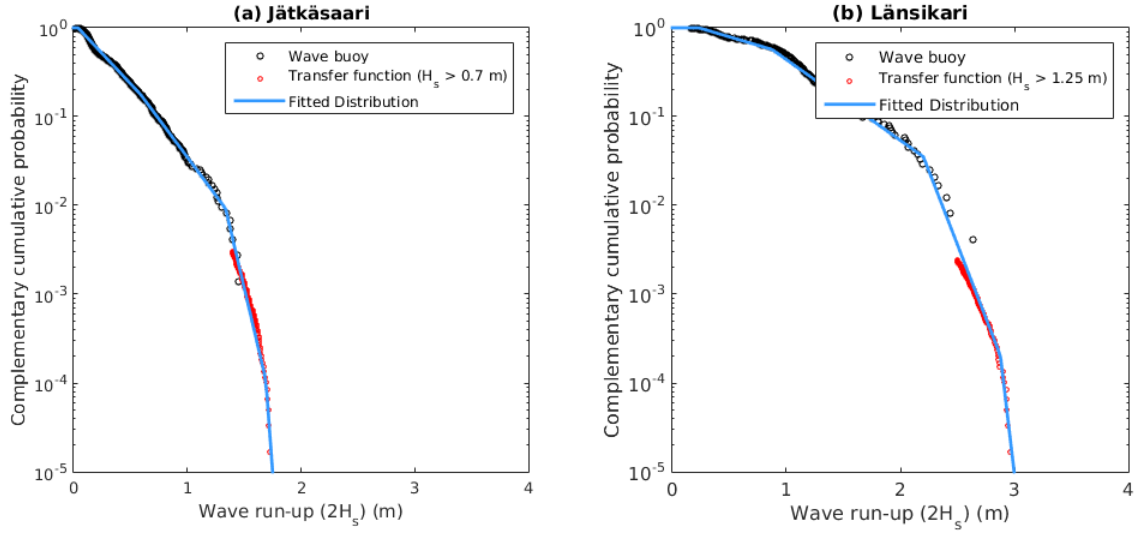

Figure 6. Wave run-up distributions for the two locations in the Helsinki archipelago: Jätkäsaari and Länsikari.

bottom topography and the numerous islands, which is why their distributions deviate from the Weibull distribution. In order to generalise the presentation of the method, we will also combine the sea level data to a set of Weibull two-parameter distributions.

5 These distributions have different properties: shape, expected value and typical magnitude relative to the sea level variations, with probability functions (pdfs and cdfs)

$$f(x, k, \lambda) = \frac{k}{\lambda} \left(\frac{x}{\lambda}\right)^{k-1} \exp\left(-\frac{x}{\lambda}\right)^k \quad (6)$$

$$F(x, k, \lambda) = 1 - \exp\left(-\frac{x}{\lambda}\right)^k, \quad (7)$$

10 where k is the shape parameter and λ is the scale parameter. We formed three distribution pairs, each having equal scale parameter and expected value, but different shape parameters (Table 1). These pairs represent three different wave conditions when compared to the still water level distribution (Fig. 7). The first pair (W1a and W1b) represents a typical sheltered situation where the wave height is small in comparison to the more dominant sea level variations. For the second pair (W2a and W2b) the waves and the sea level variations are of similar magnitude, while the third pair (W3a and W3b) represents waves that are clearly dominant compared to the sea level variations. The effect of the slightly larger shape parameter of distributions W1b, W2b and W3b compared to W1a, W2a and W3a can be seen as a slightly narrower and sharper form of the wave height

15 distributions.

Table 1. The different theoretical wave run-up distributions and observation based still water level distribution used for the theoretical test. The Weibull scale parameter (λ), shape parameter (k), expected value \mathbb{E} , 90th, 95th and 99th percentiles are given for the wave run-up distributions, and the same percentile values for the still water level distribution.

Distribution	λ	k	\mathbb{E}	90 th perc.	95 th perc.	99 th perc.
Wave1a	0.2	2.0	0.18 m	0.30 m	0.35 m	0.43 m
Wave1b	0.2	2.5	0.18 m	0.28 m	0.31 m	0.37 m
Wave2a	0.5	2.0	0.44 m	0.76 m	0.87 m	1.07 m
Wave2b	0.5	2.5	0.44 m	0.70 m	0.78 m	0.92 m
Wave3a	1.5	2.0	1.33 m	2.28 m	2.60 m	3.22 m
Wave3b	1.5	2.5	1.33 m	2.09 m	2.33 m	2.76 m
Still water level	-	-	0.00 m	0.33 m	0.45 m	0.68 m

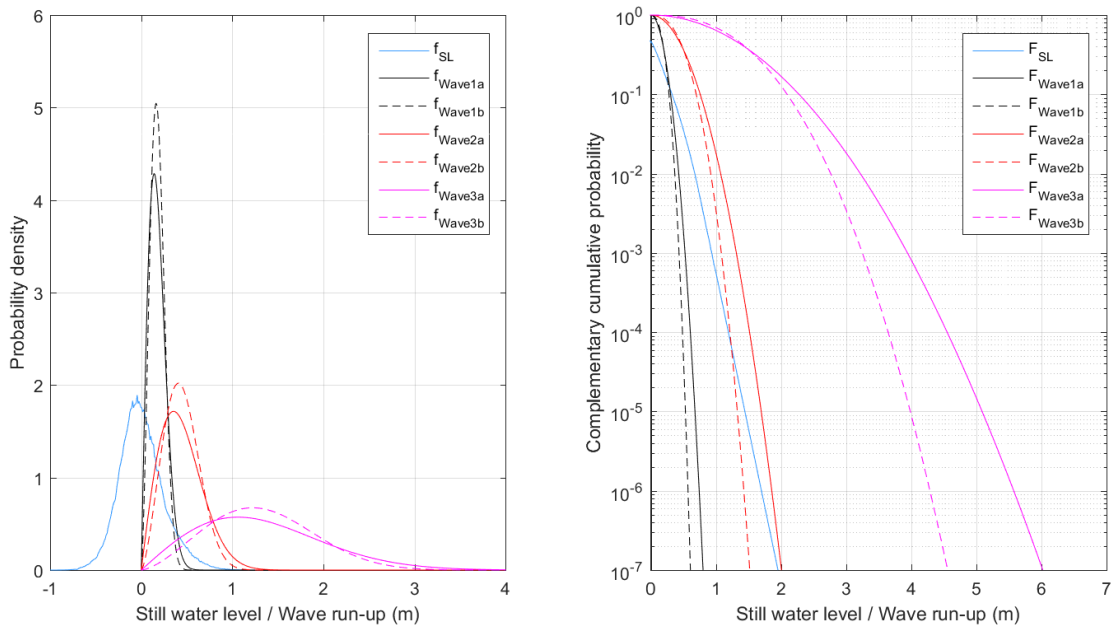

Figure 7. Pdfs (on the left) and ccdfs (on the right) for the still water level and the six theoretical wave run-up distributions.

4.4 Probability of the sum of two independent random variables

The theory for determining the probability distribution of the sum of two random variables can be found in text books (e.g. Schay, 2016), but it will nonetheless be outlined below for completeness and to introduce notation.

Let $\underline{x}, \underline{y}, \underline{z} \in \mathbb{R}$ be continuous random variables, which can take values denoted by x, y and z respectively. We use the established notation of f_x, f_y, f_z and F_x, F_y, F_z for the associated probability density functions and cumulative distribution functions (Eq. 5). We now define $\underline{z} := \underline{x} + \underline{y}$ to be the sum of the independent random variables \underline{x} and \underline{y} , while imposing no further constraints on \underline{x} or \underline{y} .

The goal is to define the cumulative distribution function F_z , namely expressing the probability $P\{\underline{z} \leq z\}$ for an arbitrary $z \in \mathbb{R}$. As \underline{z} is given as the sum $\underline{x} + \underline{y}$, it's easy to realise that $\underline{z} = z$ when $\underline{x} = \xi$ and $\underline{y} = z - \xi$ for any $\xi \in \mathbb{R}$. Consequently, $\underline{z} \leq z$ when $\underline{x} = \xi$ and $\underline{y} \leq z - \xi$, since $\underline{z} := \underline{x} + \underline{y} \leq \xi + (z - \xi) = z$. By using the assumption of independence the probability of the occurrence can be expressed as a product, thus yielding

$$\begin{aligned} P\{(\underline{x} = \xi) \wedge (\underline{y} \leq z - \xi)\} &= P\{\underline{x} = \xi\} \cdot P\{\underline{y} \leq z - \xi\} \\ &= f_x(\xi) \cdot F_y(z - \xi). \end{aligned}$$

Since this holds for any $\xi \in \mathbb{R}$ and the probability $P\{\underline{z} \leq z\}$ is a sum of all these occurrences, we can express $F_z(z)$ as the convolutions integral

$$F_z(z) = P\{\underline{z} \leq z\} = \int_{\mathbb{R}} f_x(\xi) F_y(z - \xi) d\xi = f_x * F_y. \quad (8)$$

For practical purposes f_x and F_y are usually given as discrete functions. By defining the discrete functions as

$$f_x, F_y, F_z : \{i = n \cdot \Delta\xi \mid n \in \mathbb{Z}\} \rightarrow [0, 1]$$

for some $\Delta\xi \in \mathbb{R}$ and redefining f_x as the probability mass function fulfilling $\sum_i f_x(i) = 1$, we end up with the discrete version of Eq. 8:

$$F_z(z) = \sum_{i=-\infty}^{\infty} f_x(i) F_y(z - i). \quad (9)$$

4.5 Distributions of the sum of sea level variations and wind waves

We applied the method for calculating the probability of the sum of two random variables (Sect. 4.4) to get the probability distribution of the sum of the three factors (Eq. 1) from the probability distributions of each of those (Sect. 4.1, 4.2, and 4.3).

As the first step, we calculated the cdf of the still water level ($S_L + S_S$). ~~This distribution F_{SL} , which~~ accounts for the sea level variations only ~~and will be referred to as the SL-distribution ($S_L + S_S$).~~

For the present conditions (year 2017), we calculated ~~the SL-distribution F_{SL}~~ simply by adding the long-term mean sea level estimate of ~~18.7 cm~~ 0.19 m (in the N2000 height system) to the ~~values for~~ distribution of the short-term sea level variability.

For the future (years 2050 and 2100), we calculated the ~~SL-distribution as the~~ convolution $F_{SL} = f_{SL} * F_{S_S}$ of the pdf of the long-term mean sea level scenarios (S_L) and the cdf of the short-term sea level variability (S_S). ~~Still water levels corresponding to certain frequencies of exceedance are shown in Table 2~~

Finally, we calculated a still water level distribution to be used in the theoretical test by simply taking the distribution of the short-term sea level variability (S_S) as such. This resulted in a distribution where the variability equals present-day short-term variability, but the mean (or expected value) is zero.

As a second step, we calculated the cdf of the full three-component sum (Eq. 1). By using the notations from Sect. 4.4, \underline{x} is the still water level $S_L + S_S$, \underline{y} is the run-up H_{runup} , and \underline{z} is the ~~elevation to which the continuous water mass reaches, total water level~~ H . Since the method is symmetric, the choice of \underline{x} and \underline{y} is in theory arbitrary. In practice, more data are required to get a good estimate of the pdf f_x , which guides the proper choice of variables. We had significantly more sea level data available and will for the remainder of this paper adopt the notation f_{SL} ("sea level") and F_W ("wave") for f_x and F_y in Eq. 9. The ~~combined cumulative function distribution of the total water level~~ obtained using convolution and corresponding to F_z in Eq. 9 will be denoted $F_{SL,W} = f_{SL} * F_W$. ~~The resulting distribution will be referred to as the SL,W-distribution~~

This calculation of the three-component sum was performed for the still water level distributions for 2017, 2050 and 2100 combined with the observation-based wave run-up distributions at Jätkäsaari and Länsikari, as well as for the zero-mean still water level distribution combined with the six theoretical wave run-up distributions.

5 Results

5.1 Case study in Helsinki Archipelago

We applied the presented method in the Helsinki Archipelago, located at the northern coast of the Gulf of Finland, Baltic Sea. The calculations were done for two locations, where Jätkäsaari is situated deep inside the archipelago near the shoreline, while Länsikari is more exposed to the open sea wave conditions (Fig. 2).

We calculated F_{SL} for the still water level as a sum of two components: the short- and long-term sea level variations. Still water levels corresponding to certain frequencies of exceedance are shown in Table 2. In the convolutions $F_{SL,W}$, the wave run-up was additionally accounted for, as they were calculated as a sum of three components as outlined in Sect. 4. We calculated the distributions both for the present conditions (2017), and for the future scenarios in 2050 and 2100 (Fig. ??). The total water levels representing the maximum elevation of the continuous water mass on a steep shore with selected frequencies of exceedance are given in Table 3.

The total water levels for a location closer to the open sea (Länsikari) are up to 1.2 m higher compared to the values for the sheltered shore location (Jätkäsaari). This clear difference follows from the difference in the wave run-up distributions (see Fig. 6), and highlights the variability of the waves due to locational differences, even in a rather small coastal area under investigation.

The impact of the future mean sea level change is evident in the F_{SL} distributions for the three different years (Fig. ??). The still water levels corresponding to certain frequencies of exceedance change only slightly from 2017 to 2050, but increase

Still water levels (in m relative to N2000) corresponding to certain frequencies of exceedance for three years (2017, 2050 and 2100) based on the observed sea level variability and mean sea level scenarios for the Helsinki tide gauge.

Table 2. Still water levels (in m relative to N2000) corresponding to certain frequencies of exceedance for three years (2017, 2050 and 2100) based on the observed sea level variability and mean sea level scenarios for the Helsinki tide gauge.

		Helsinki tide gauge		
		Projection year		
		2017	2050	2100
<u>Frequency of exceedance (events/year)</u>	<u>Frequency of exceedance (events/year)</u>	Still water level (m)		
	1/1	1.36	1.49	2.33
	1/50	1.80	1.92	2.87
	1/100	1.87	2.00	2.95
	1/250	1.97	2.10	3.06

significantly more from 2050 to 2100. From 2050 to 2100, the 1/1 events/year still water level increases by 0.84 m, and the 1/250 events/year still water level by 0.96 m (Table 2). This change results from the projected accelerating mean sea level rise in the Gulf of Finland, as well as from the wider uncertainty range in the mean sea level projections for 2100, which is reflected in the mean sea level probability distribution (for details, see Pellikka et al., 2018).

5 As we used the same mean sea level scenario for both Jätkäsaari and Länsikari, the effect of the mean sea level change is similar for them even in the $F_{SL,W}$ distributions. For example, the total water levels exceeded by 1/100 events/year increase by 0.86 m in Jätkäsaari and 0.83 m in Länsikari from 2050 to 2100. The small difference between the two study locations results from the slightly different shape of the wave run-up distributions.

6 Sensitivity of the method on the shape of the wave distribution

10 The wave run-up distributions used in this study are experimental fits to the available wave data at different locations. For this, we wanted to test more generally how different wave height conditions influence the resulting joint effect of sea level and waves when the sea level distribution is kept unchanged. We therefore constructed six different theoretical wave run-up distributions with known parameters to quantify the effects of different properties of the wave distributions (shape, expected value and typical magnitude relative to the sea level variations) on the distribution of the sum of waves and sea level.

15 5.1 Setup of the sensitivity analysis

The theoretical wave run-up distributions were constructed as two-parameter Weibull distributions, which have probability functions (pdfs and edfs)

Table 3. Total water levels (m relative to N2000), as the sum of still water level and wave run-up, for three different years (2017, 2050 and 2100) for Jätkäsaari and Länsikari.

$f(x, k, \lambda) = \frac{k}{\lambda} \left(\frac{x}{\lambda}\right)^{k-1} \exp\left(-\frac{x}{\lambda}\right)^k$	Frequency
	<u>1/1</u>
	<u>1/50</u>
	<u>1/100</u>
	<u>1/250</u>
$F(x, k, \lambda) = 1 - \exp\left(-\frac{x}{\lambda}\right)^k$	

where k is the shape parameter and λ is the scale parameter. Our six wave height distributions form three pairs, where each pair has an equal expected value, but slightly different shape parameters k (Table ??).

The three wave run-up pairs represent three different wave conditions. The first pair (W1a and W1b) represents a typical sheltered situation where the wave height is small in comparison to the more dominant sea level variations. For the second pair (W2a and W2b) the waves and

5.1 Test with theoretical wave run-up distributions, and the same percentile values for the still water level distribution.

Distribution-

The probability density functions of the still water level distribution and the six different wave The total water level distributions SL, W1a etc., obtained by combining the distribution of the short-term still water level with the theoretical wave run-up distributions-

Comparison of the test outcomes and their relation to a theoretical framework distributions, are shown in Fig. 9. We chose four different frequencies of exceedance (1/1, 1/50, 1/100 and 1/250 events/year) for a closer examination. Table ??-4 summarizes these for the still water level distribution and the six wave run-up distributions, as well as for the sum of these i.e. the run-up total water level distributions. As a comparison, also the corresponding still water levels added to the expected values of the wave run-up distributions are shown.

For the first pair, the sea level variations are clearly dominating the wave variations of wave run-up distributions (W1a and W1b, see Table ??). The run-up 1), the sea level variations clearly dominate the wave variations. The total water levels are mostly set by the still water levels; the distribution of the sum of the sea level and the wave run-up produces total water levels

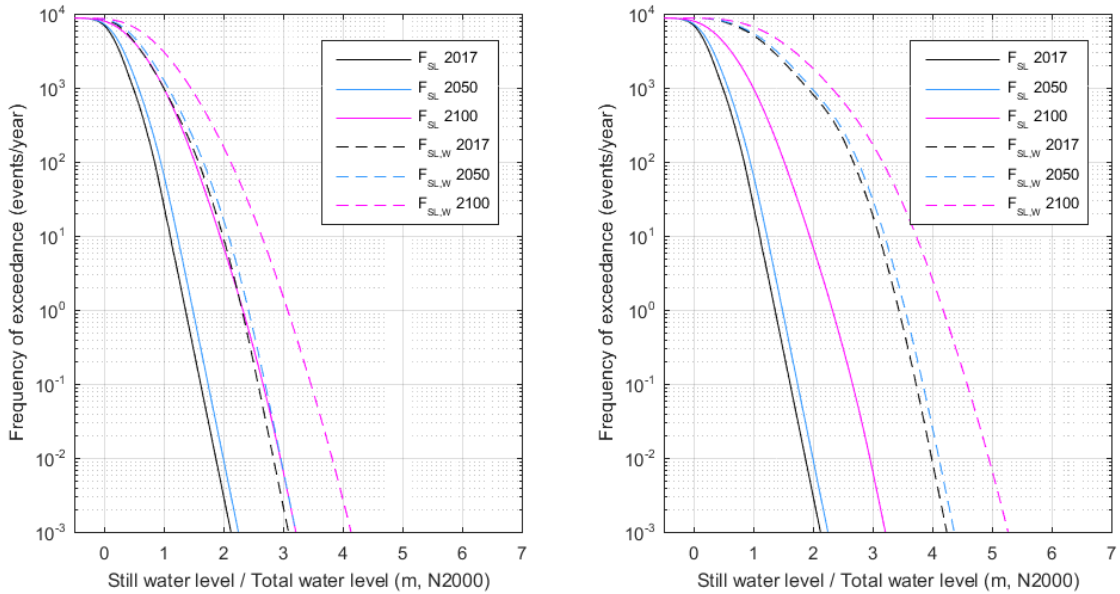

An overview of the different distributions, their parameters and properties is found in Table ???. The probability density functions are plotted in Fig. 7, which gives a visual comparison of the different wave height situations in relation to the sea level variations. The effect of the slightly larger shape parameter of distributions W1b alone (F_{SL}), W2b and W3b compared to W1a, W2a and W3a can be seen as a slightly narrower and sharper form of the wave height distributions.

We performed all the calculations using the wave height cdfs and the sea level pdf, as reasoned above in Sect. 4.5. Wave run-up heights were summed with the still water levels. The distribution of the sum of these two variables i.e. the run-up level distribution is labeled $SL,W1a$, where $F_{SL,W1a} = f_{SL} * F_{W1a}$ (see Eq. 8).

The different theoretical wave run-up distributions and observation-based sum of the still water level distribution used for the sensitivity test. The Weibull scale parameter and wave run-up ($\lambda F_{SL,W}$) for three different years (2017, shape parameter 2050 and 2100) at the two case study locations: Jätkäsaari (on the left), expected value \mathbb{E} , 90th, 95th and 99th percentiles are given for Länsikari (on the right).

An overview of the different distributions, their parameters and properties is found in Table ???. The probability density functions are plotted in Fig. 7, which gives a visual comparison of the different wave height situations in relation to the sea level variations. The effect of the slightly larger shape parameter of distributions W1b alone (F_{SL}), W2b and W3b compared to W1a, W2a and W3a can be seen as a slightly narrower and sharper form of the wave height distributions.

We performed all the calculations using the wave height cdfs and the sea level pdf, as reasoned above in Sect. 4.5. Wave run-up heights were summed with the still water levels. The distribution of the sum of these two variables i.e. the run-up level distribution is labeled $SL,W1a$, where $F_{SL,W1a} = f_{SL} * F_{W1a}$ (see Eq. 8).

The different theoretical wave run-up distributions and observation-based sum of the still water level distribution used for the sensitivity test. The Weibull scale parameter and wave run-up ($\lambda F_{SL,W}$) for three different years (2017, shape parameter 2050 and 2100) at the two case study locations: Jätkäsaari (on the left), expected value \mathbb{E} , 90th, 95th and 99th percentiles are given for Länsikari (on the right).

Figure 8. Cdfs for the sea level variations are of similar magnitude, while the third pair (W3a and W3b) represents waves that are clearly dominant compared to the sea level variations. The sea level distribution used in the sensitivity analysis was based on 46 years of observations (see Sect. 4.2). We call the sea level distribution the still water level distribution SL and denote the wave height distributions by wave run-up distributions W1a, W1b etc.

An overview of the different distributions, their parameters and properties is found in Table ???. The probability density functions are plotted in Fig. 7 which gives a visual comparison of the different wave height situations in relation to the sea level variations. The effect of the

Table 4. Results of the theoretical test i.e. values for different frequencies of exceedance for the still water level distribution SL, the six theoretical wave run-up distributions W1a-W3b, and the total water level distributions SL.W1a (the convolution $f_{SL} * F_{W1a}$). The total water levels resulting from the sum of still water level and expected value of the wave run-up distributions are marked by SL+E(W1a).

Distributions	λ Frequency of exceedance (events/year)			
	$\lambda=1/1$ 99 th perc.	$\lambda=1/50$	90 th perc. 1/100	95 th perc. 1/250
	Still water level (m)			
Wave1a-SL	0.2-1.18 0.35 m	2.0-1.61	0.18 m-1.69	0.30 m-1.79
	Wave run-up (m)			
W1a	0.43 m-0.60	0.72	0.74	0.76
Wave1b-W1b	0.2-0.48	2.5-0.56	0.18 m-0.57	0.28 m-0.59
W2a	0.31 m-1.51	0.37 m-1.80	1.85	1.91
W2b	1.21	1.39	1.42	1.46
W3a	4.52	5.41	5.55	5.73
W3b	3.63	4.18	4.27	4.38
	Total water level (m)			
Wave2a	0.5			
SL.W1a	2.0-1.40	0.44 m-1.83	0.76 m-1.91	0.87 m-2.01
SL.W1b	1.07 m-1.38	1.81	1.89	1.99
Wave2b-SL.W2a	0.5-1.95	2.5-2.40	0.44 m-2.48	0.70 m-2.58
SL.W2b	0.78 m-1.81	0.92 m-2.24	2.32	2.42
SL.W3a	4.66	5.58	5.73	5.92
SL.W3b	3.84	4.48	4.58	4.71
Wave3a-SL+E(W1a)	1.5-1.35	2.0-1.79	1.33 m-1.86	2.28 m-1.96
SL+E(W1b)	2.60 m-1.35	3.22 m-1.79	1.86	1.96
Wave3b-SL+E(W2a)	1.5-1.62	2.5-2.05	1.33 m-2.13	2.09 m-2.23
SL+E(W2b)	2.33 m-1.62	2.76 m-2.05	2.13	2.23
Still water level-SL+E(W3a)	-2.51	-2.94	0.00 m-3.01	0.33 m-3.12
SL+E(W3b)	0.45 m-2.51	0.68 m-2.94	3.02	3.12

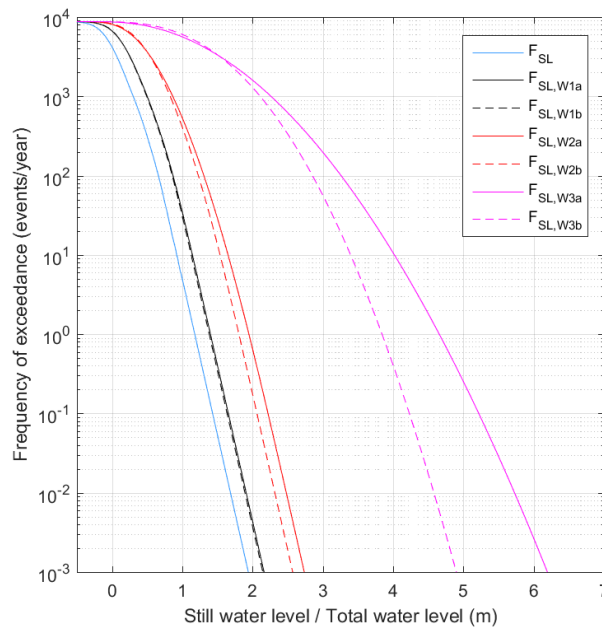

Figure 9. Ccdfs for the still water level and the total water level, obtained by applying six theoretical wave run-up distributions.

at certain frequencies of exceedance are about 0.2 m higher values in comparison to the than the corresponding still water levels alone. In this setting, the effect of The effect of the different shapes of the wave run-up distributions W1a and W1b on the results is negligible.

In the second pair (W2a and W2b), neither the wind waves nor the sea level variations are clearly dominant (W2a and W2b, see Table ??). The contribution of the waves is now significant larger compared to the first pair. Even the run-up total water level with a frequency of 1/1 events/year for the SL,W2a (1.95 m) is larger than the still water level with a frequency of 1/250 events/year (1.79 m). The effect of the shapes of the wave distributions is no longer negligible for the second pair. The distribution W2a has a thicker tail compared to distribution W2b, meaning that the higher values are more probable. The difference in the run-up total water level with a frequency of exceedance of 1/250 events/year between SL,W2a and SL,W2b is already 0.2 m (Table ??). This difference is caused solely by the different shapes of the wave distributions W2a and W2b, since they have the same expected value and the sea level distribution was identical in both cases.

In the case of the third pair (W3a and W3b), the contribution of the larger waves becomes evident. The run-up levels of the sum of sea level and waves total water levels are up to 3.5 m (1/1 events/year) and 4.1 m (1/250 events/year) higher compared to the still water levels alone. There is a The still water levels increase by 0.6 m difference in still water level when comparing the frequencies m from the frequency of 1/1 events/year and to 1/250 events/year, but the increase in the corresponding run-up levels is up to 1.3 total water levels is 0.9–1.3 m (Table ??). Unlike for the previous in the other cases, the effect of the wave distribution's shape factor on the run-up shape factor of the wave distribution on the total water level increases with smaller

decreasing frequencies of exceedance, and is up to being 1.2 m for frequency of 1/250 events/year. This shape related behavior can be seen explicitly in Fig. 9.

The sensitivity test reveals that the dominant component determines strongly the run-up level of the distribution of the sum. In addition to the remarks above, this effect is evident as the still water levels are rather close to the run-up levels SL,W1a and SL,W1b (the case where sea level variations are dominant), and on the other hand as the third wave run-up pair W3a and W3b constitutes mostly the run-up levels SL,W3a and SL,W3b (the case where waves dominate over sea level variations) (Table ??).

The distribution of the run-up levels is determined by the relative magnitude of the components, which is in accordance with the properties of the probability of the sum of two independent random variables. The expected value of the sum of two such variables is the sum of the expected values of the components, and the variance is the sum of the variances of the individual components. For this reason, the larger component dominates strongly in the standard deviation of the sum:

$$\sigma = \sqrt{\sigma_{SL}^2 + \sigma_W^2},$$

where σ_{SL} is the standard deviation of the still water level distribution and σ_W is the standard deviation of the wave run-up distribution. Since the mean of the still water level distribution is zero (see Table ??) the expected value of the distribution of the sum will be determined by the waves. The run-up level z corresponding to the cumulative probability P can therefore be written as

$$z(P) = \mathbb{E}(W) + \xi_{SL,W}(P) \cdot \sqrt{\sigma_{SL}^2 + \sigma_W^2},$$

where $\xi(P)$ is a coefficient depending on the shape of the distribution. When the sea level variations dominate, i.e. $\sigma_{SL} \gg \sigma_W$, the shape of the distribution is also mainly determined by the still water level distribution, and we can approximate Eq. ?? by

$$z(P) \approx \mathbb{E}(W) + \xi_{SL}(P) \cdot \sigma_{SL},$$

where $\mathbb{E}(W)$ takes the role of a "fixed wave action height". Equation ?? shows that $\mathbb{E}(W)$ is only "fixed" at locations with similar wave conditions. As long as the sea level variations dominate ($\sigma_{SL} \gg \sigma_W$), and the coefficient ξ depends on the still water level distribution, there is no need to calculate the distribution of the sum to define the run-up level. However, if σ_W is not negligible compared to σ_{SL} , the coefficient $\xi_{SL,W}$ will differ from ξ_{SL} . The approximation in Eq. ?? will no longer be valid and the full distribution of the sum needs to be identified in order to account for the waves. is evident in Fig. 9.

If both probability distributions under investigation are normal (Gaussian) distributions, the distribution of the sum is also Gaussian. In this case, $\xi(P)$ is similar for each of them, and we get the simple equation (??) for the run-up level. Weibull and exponential distributions are sufficiently close to the normal distribution that we can expect that also in their case the run-up level can in practice be defined by using this simple form, provided that still water level variations dominate sufficiently.

In our sensitivity test (Table ??) the run-up levels of the sum of sea level and waves ~~With the first pair, the total water levels~~ (SL,W1a and SL,W1b) differed at most 0.1 m from the ~~run-up levels based on the sum of sum of the~~ still water levels and expected values of the wave run-up distributions, namely $SL+\mathbb{E}(W1a)$ and $SL+\mathbb{E}(W1b)$. Thus, in ~~a this~~ situation where the sea level variations dominate, simply adding the expected value of the wave run-up distribution on top of the still water levels produces results quite similar to those based on the distribution of the sum. ~~In this situation, the simplified equation ?? works pretty well for the Weibull distributed random variables used in the sensitivity test~~ The effect of waves on the total water level reduces to a "fixed wave action height", which can be approximated with the expected value of the wave run-up distribution. In such cases, there is no need to calculate the distribution of the sum to obtain a good approximation of the distribution.

However, as soon as the contribution of the waves increases, the situation changes. In the equal wave-sea level situation (SL,W2a and SL,W2b vs. $SL+\mathbb{E}(W2a)$ and $SL+\mathbb{E}(W2b)$), simply adding the expected value of the wave run-up distribution on top of the still water levels would underestimate the ~~run-up total water~~ levels by up to 0.4 m compared to the distribution of the sum. However, when looking at the difference between the still water levels and the ~~run-up levelsof the sum of sea level and waves~~ total water levels, we notice that the effect of the waves can still be quantified almost as a constant value to be added on top of the still water levels, "fixed wave action height", for all the four frequencies of exceedance under inspection. However, the distribution of the sum still needs to be calculated to obtain this value, as it exceeds the expected value.

Finally, ~~a similar comparison for in~~ the case where the waves dominate (SL,W3a and SL,W3b vs. $SL+\mathbb{E}(W3a)$ and $SL+\mathbb{E}(W3b)$) ~~results in significant~~ there are large differences (up to 2.8 m), showing that the simplified solution of adding the expected value of the wave run-up distribution on top of the still water levels would lead to a ~~significant~~ remarkable underestimation of the ~~run-up total water~~ level. Moreover, it is clear that ~~for in~~ this situation the effect of the waves cannot be quantified as a constant value to be added on top of the still water levels ~~for the frequencies of exceedance ranging from 1/1 to 1/250 events/year.~~

~~Sensitivity test results for different frequencies of exceedance for the still water level distribution SL, the six theoretical wave run-up distributions W1a-W3b, and the run-up level distributions SL,W1a, i.e. the convolution $f_{SL} * F_{W1a}$. The run-up levels resulting from the sum of still water level and expected value of the wave run-up distributions are marked by $SL+\mathbb{E}(W1a)$. Distributions 1/1 1/50 1/100 1/250~~

~~SL-1.18 1.61 1.69 1.79
W1a 0.60 0.72 0.74 0.76 W1b 0.48 0.56 0.57 0.59 W2a 1.51 1.80 1.85 1.91 W2b 1.21 1.39 1.42 1.46 W3a 4.52 5.41 5.55 5.73 W3b 3.63 4.18 4.27 4.38
SL,W1a 1.40 1.83 1.91 2.01 SL,W1b 1.38 1.81 1.89 1.99 SL,W2a 1.95 2.40 2.48 2.58 SL,W2b 1.81 2.24 2.32 2.42 SL,W3a 4.66 5.58 5.73 5.92 SL,W3b 3.84 4.48 4.58 4.71 SL+ \mathbb{E} (W1a) 1.35 1.79 1.86 1.96 SL+ \mathbb{E} (W1b) 1.35 1.79 1.86 1.96 SL+ \mathbb{E} (W2a) 1.62 2.05 2.13 2.23 SL+ \mathbb{E} (W2b) 1.62 2.05 2.13 2.23 SL+ \mathbb{E} (W3a) 2.51 2.94 3.01 3.12 SL+ \mathbb{E} (W3b) 2.51 2.94 3.02 3.12~~

~~The cumulative probability distribution functions for the observation-based sea level variability and the sum of sea level and waves, obtained by applying six different theoretical significant wave height distributions:~~

6 Results of the case study in Helsinki Archipelago

5.1 Comparison of the theoretical test with the case study results

We applied the presented method in the Helsinki Archipelago, located at the northern coast of the Gulf of Finland, Baltic Sea. The calculations were done for two locations, where The observed wave run-up distribution at Jätkäsaari is situated deep inside the archipelago near the shoreline, while Länsikari is more exposed to the open-sea wave conditions (Fig. 2).

We calculated the SL-distributions for the still water level as a sum of two components: the short- and long-term sea level variations. In the SL,W-distributions, the wave run-up was additionally accounted for, as they were calculated as a sum of three components as outlined in Sect. 4. These distributions are illustrated in Fig. ???. We calculated the distributions both for the present conditions (2017), and for the future scenarios in 2050 and 2100. The run-up levels representing the maximum elevation of the continuous water mass on a steep shore with selected frequencies of exceedance are given in Table 3.

The run-up levels for a location closer to the open sea (6) is closest to the second pair (W2a, W2b) of the theoretical distributions (Fig. 7), while the distribution at Länsikari) are up to 1.2 m higher compared to the values for the sheltered shore location (Jätkäsaari). This clear difference follows from the difference in the wave run-up distributions (see Fig. 6), and highlights the variability of the waves due to locational differences, even in a rather small coastal area under investigation.

The sensitivity test (Sect. ??) showed that the dominant component determines strongly the run-up level of falls between the second and third (W3a, W3b) pairs of the theoretical distributions. In both locations, the contribution of waves on the total water levels in 2017 can be quantified with a virtually constant addition to the distribution of the sum, which results from the properties of the probability of the sum of two independent random variables. For the sheltered shore location (still water levels: 0.95–0.97 m in the case of Jätkäsaari) the run-up is mostly set by the still water level (Table 2), whereas for the study location exposed to open sea (, and 2.08–2.12 m for Länsikari) the contribution of waves becomes more significant.

The sensitivity test also revealed that in a situation where the sea level variability dominates, the effect of the waves could be quantified as a constant addition on top of the still water levels exceeded with different frequencies, but not for the case . Even Länsikari, where the wave run-up was clearly dominant in comparison to variations somewhat dominate the sea level variations. The case study results for 2017 and 2050 show the same effect, as the difference between the still water levels in the SL-distributions and the run-up levels in the SL,W-distributions is almost independent of the variability, does not show the behaviour characteristic for the third theoretical pair: the increase of the effect of waves with decreasing frequency of exceedance (Tables 2 & 3). This difference — representing the effect of the wave run-up — varies only up to 6 cm between the frequencies of exceedance from 1/1 to 1/250 events/year. Even in the 2100 scenario, this difference only varies up to 17 cm, a small value compared to the total effect of the waves which is of the order of 1–2 m.

The impact of the future mean sea level change is evident in the SL-distributions for the three different years (Fig. ??). The still water levels corresponding to certain frequencies of exceedance change only slightly from 2017 to 2050, but increase significantly more from 2050 to 2100. From

This same applies for the distributions of the total water level in 2050: the effect of waves adds 0.93–0.96 m to 2100, the 1/1 events/year the still water level increases by 84 cm, and the 1/250 events/year still water level by 96 cm (Table 2). This change

results from the predicted accelerating mean sea level rise in the Gulf of Finland, as well as from the wider uncertainty range in the mean sea level projections distribution at Jätkäsaari, and 2.05–2.11 m at Länsikari. The distributions for 2100, which is reflected in the mean sea level probability distribution (for details, see Pellikka et al., 2018).

As we used the same mean sea level scenario for both however, behave differently. For them, the contribution of waves increases with decreasing frequency of exceedance: from 0.74 to 0.89 m at Jätkäsaari and, and 1.85 to 2.02 m at Länsikari, the effect of the mean sea level change is similar for them even in the SL,W-distributions. For example, the run-up levels exceeded by 1/100 events/year increase by 86 cm in. It is also noteworthy that the contribution of waves is smaller in 2100 than in 2017 or 2050.

The effect of waves on the distributions of the total water level at Jätkäsaari and 83 cm in Länsikari from in 2017 and 2050 to 2100. The small difference between the two study locations results from the slightly different shape can thus be quantified with a "fixed wave action height" but, likewise to the theoretical distributions SL,W2a and SL,W2b, this value clearly exceeds the expected value of the wave run-up distributions distribution.

Cedfs for the still water level alone (F_{SL}), and the sum of the still water level and wave run-up ($F_{SL,W}$) for three different years (2017, 2050 and 2100) at the two case study locations: Jätkäsaari (on the left) and Länsikari (on the right):

Run-up levels (m relative to N2000), as the sum of still water level and wave run-up, for three different years (2017, 2050 and 2100) for Jätkäsaari and Länsikari. **2017 2050 2100 2017 2050 2100**

Frequency of exceedance (events/year) 1/1 2.31 2.42 3.07 3.44 3.54 4.18 1/50 2.76 2.88 3.72 3.91 4.03 4.84 1/100 2.84 2.96 3.82 3.99 4.11 4.94 1/250 2.94 3.06 3.95 4.09 4.21 5.08

6 Discussion

6.1 Conditions and applicability of the method

In general case, the relationships between the wave height, wave run-up, and sea level variations are complex. In this study, we made several assumptions and simplifications. The aim of this section is to discuss the validity of our results, and also help the reader to estimate whether this method could be used in a certain location or with a specific data available.

The essential prerequisites for applying the method presented above are:

1. An estimate for the long-term mean sea level is needed. In its simplest form, this can be a single mean sea level height value. If the mean sea level is changing, however, an estimate for this change is needed. Again, a simple estimate could be a time-dependent mean sea level value; a linear trend, for instance. Using an ensemble of estimates, the way we did with for the future scenarios (like was done by Pellikka et al. (2018)), however, leads to a time-dependent probability distribution for the mean sea level, which. Such distribution contains more information on the different possible future pathways.
2. An estimate for the range of the short-term sea level variability is needed; technically, in the form of a good-quality probability density function. In the case of the Finnish coast, we have found that several decades of observations with

hourly time resolution are needed to get a reliable estimate for the extent of the local sea level variations. Additionally, to estimate ~~run-up~~ total water levels with low frequencies of exceedance, such as 1/250 events/year used in this study, the observation-based probability distribution – rarely extending down to frequencies below 1/100 events/year – needs to be extrapolated using suitable extreme value analysis methods.

- 5 3. An estimate for the wave run-up distribution is needed to account for the effect of waves on the coast. In this paper we have used the simplest formula for a steep shore using the highest single wave, which was estimated from the significant wave height H_s . The method can be generalised by using wave run-up formulations that also account for e.g. the slope of the beach.
- 10 4. We based our analysis on a simplifying assumption that the sea level variations and wave run-up are independent. This makes it possible to calculate the distribution of the sum from the marginal distributions without additional assumptions. In practice, the independence of the variables can be, at least partly, achieved for locations with a constant beach profile, such as deep and steep shores. Strong wind-independent components in the sea level also decrease the dependence of the sea level and the wave run-up. In the Baltic Sea, such component is the total Baltic Sea water volume which, although expressing a strong correlation with the wind conditions (Johansson et al., 2014), does so in a time scale much longer
15 than that of the wind waves. In addition, the mutual dependence of the sea level and waves is weakened in the Gulf of Finland, since strong easterly winds lower the sea level by emptying the gulf. Tidal variations are also a sea level component which is independent of waves; such variations are small on the Finnish coast, however.

As long as the above conditions are met, we consider the method presented here applicable also for other places than the Finnish coast. Naturally, as the most important factors causing sea level variations are different in different places, this needs
20 to be taken into account. For instance, in places where the tidal variations dominate over storm surges, a different analysis of the short-term sea level variability might be appropriate.

6.2 Limitations and potential improvements

In our approach, we treated the still water level variations and the wave run-up as independent variables as a first approximation. The limited amount of wave data available for this study imposed challenges in the construction of the full joint distribution,
25 which would have taken into account the possible dependencies between these variables. The dependency might be affected by the ~~location-specific~~ location-specific circumstances, and further studies are needed to determine the conditions under which the use of the full two dimensional distributions is preferable to assuming independence.

~~Block maxima — such as monthly maxima — have often been used for the extreme value analysis of sea level variations. However, this implicitly restricts the study of the joint effect to cases where the still water level is high, thus excluding
30 combinations of a moderate still water level and high waves. The impact on the end result is therefore expected to be influenced by the relative importance of the two phenomena.~~

~~Pellikka et al., 2017~~ Pellikka et al. (2018) used the observed monthly maxima of sea levels on the Finnish coast to calculate the location-specific short-term sea level variability distributions. They calculated the probability distribution of the sum

of long- and short-term sea level variations with a method similar to the one we used to calculate the ~~SL-distribution~~ F_{SL} ~~distribution~~. By this method they analyzed the present and future flooding risks on the Finnish coast. Our results for still water levels with frequencies of exceedance of 1/1, 1/50 and 1/100 events/year (Table 2) are higher than those of ~~Pellikka et al., 2017~~ Pellikka et al. This is ~~mostly likely~~ explained by the differences in statistics. Several high hourly sea level values can occur during the same month, or even the same storm surge event, and still result into only one monthly maximum in the statistics. Thus, the hourly values have a higher frequency of exceedance than the monthly maxima, reflecting the difference in the definition of "an event" in each case.

Using block maxima of sea level variations – such as the monthly maxima used by Pellikka et al. (2018) – in our analysis would implicitly restrict the study of the joint effect to cases where the still water level is high, thus excluding combinations of moderate still water level and high waves.

We calculated the future scenarios for the flooding risks by simply combining the mean sea level scenarios with the present-day short-term sea level variability and wave conditions. Thus, we implicitly assumed that those will not change in the future. A potential improvement, to get deeper insight into the changes of flooding risks in the future, would be to include scenarios of short-term sea level variability or wave conditions. As these both mainly depend on short-term weather (wind and air pressure) conditions, this would require scenarios for the short-term weather variability.

Safe coastal building elevations are usually estimated for structures with a designed lifetime of at least several decades, but the relevant safety margins differ between commercial buildings, residential buildings and e.g. nuclear power plant sites. We therefore need to consider scenarios up to 2100 and frequencies of exceedance as rare as 1/250 events/year or even less. The approach presented in this paper allows for the determining of different building levels based on the acceptable risks for various infrastructure, thus reducing building costs while maintaining necessary safety margins. Thereby it assists in a cost-effective coastal planning to meet the requirements of changing climate of the future.

7 Conclusions

In this study, a location-specific statistical method was used for the first time on the Finnish coast for evaluating flooding risks based on the joint effect of three ~~different~~ components: 1) long-term mean sea level change, 2) short-term sea level variability, and 3) wind-generated waves. We conducted an observation-based case study for two locations with steep shorelines, and performed a ~~sensitivity~~ test with theoretical wave run-up distributions. ~~The probability distributions of the sum of the three aforementioned components were calculated, giving the elevations to which the continuous water mass can rise as a result of still water level and the wind-wave run-up. Such probability distribution provides direct run-up level estimates for different frequencies of exceedance, which enables an easy evaluation of different risk levels for coastal building.~~

The case study at the Helsinki Archipelago (Sect. 5) showed that the ~~joint run-up levels for a location exposed to flooding risk estimates are sensitive to local wave conditions: the total water levels at the site close~~ the open sea (Länsikari) ~~are were~~ clearly higher compared to the values ~~for at~~ the sheltered location near the shoreline (Jätkäsaari). This finding ~~supports~~ highlights the

need for a location-specific evaluation of the wave height to prevent over- ~~and or~~ underestimation of the joint effect, especially in places with an irregular coastline.

~~The effect of the mean sea level scenario on the run-up levels at different frequencies of exceedance at the case study sites is moderate in 2050, but more prominent in 2100. This~~ We found the coastal flooding risks in our case study location to increase towards the end of the century. This behavior in our results is due to the ~~predicted acceleration of the projected~~ mean sea level rise as well as ~~the increasing uncertainties in the future, resulting in a wider probability distribution. Pellikka et al., 2017 have discussed these scenarios in more detail. According to the case study presented here, the coastal flooding risks including the simultaneous effect of sea level and waves are significantly higher in the end of the century compared to the current state. However, the run-up levels estimated these projections (Pellikka et al., 2018). It is noteworthy that the frequencies of exceedance given for certain total water levels in our distributions~~ for 2100 do not ~~form the expected run-up level distribution for that year, but include the uncertainty of the future mean sea level rise. Thus, the run-up levels with certain frequency of exceedance in 2100 are just statistical estimates accounting for all the~~ represent the actual flooding risk in that year. Instead, they are statistical estimates, which include the uncertainty due to the range of possible mean sea level scenarios. Eventually, only one of which will eventually (or none) of these scenarios will be realized in 2100.

Our test with the theoretical wave run-up distributions showed that in a situation where the sea level variations dominate over waves, simply adding the expected value of the wave run-up on top of the still water level distribution produces results close to the distribution of the sum. However, when the contribution of the waves increases, such addition leads to an underestimation of the effect of waves on the total water levels. Finally, when the waves are clearly dominant, their effect starts to depend on the frequency of exceedance and cannot be quantified as a constant value to be added on top of the still water levels anymore.

~~Safe coastal building elevations are usually estimated for structures with a designed lifetime of at least several decades, but the relevant safety margins differ between commercial buildings, residential buildings and e.g. nuclear power plant sites. We therefore need to consider scenarios up to 2100 and frequencies of exceedance as rare as 1/250 events/year or even less. The approach presented in this paper allows the evaluation of separate risk levels for different coastal infrastructures, and thereby assists in a cost-effective coastal planning to meet the requirements of changing climate of the future.~~

25 *Competing interests.* No competing interests are present.

Acknowledgements. This research was partly funded by: the Finnish State Nuclear Waste Management Fund (VYR) through SAFIR2018 (the Finnish Research Programme on Nuclear Power Plant Safety ~~2015-2108~~2015-2018); The City of Helsinki, and Arvid och Greta Olins fond (Svenska kulturfonden, 15/0334-1505).

References

- [Battjes, J. A.: Long-term wave height distributions at seven stations around the British Isles, *Deutsche Hydrographische Zeitschrift*, 25, 179–189, <https://doi.org/https://doi.org/10.1007/BF02312702>, 1972.](https://doi.org/https://doi.org/10.1007/BF02312702)
- 5 Björkqvist, J.-V., Tuomi, L., Fortelius, C., Pettersson, H., Tikka, K., and Kahma, K. K.: Improved estimates of nearshore wave conditions in the Gulf of Finland, *J. Marine Syst.*, 171, 43–53, <https://doi.org/10.1016/j.jmarsys.2016.07.005>, 2017a.
- Björkqvist, J.-V., Tuomi, L., Tollman, N., Kangas, A., Pettersson, H., Marjamaa, R., Jokinen, H., and Fortelius, C.: Brief communication: Characteristic properties of extreme wave events in the Baltic Sea, *Natural Hazards and Earth System Sciences Discussions*, 2017, 1–8, <https://doi.org/10.5194/nhess-2017-117>, <https://www.nat-hazards-earth-syst-sci-discuss.net/nhess-2017-117/>, 2017b.
- 10 Björkqvist, J.-V., Vähäaho, I., and Kahma, K.: Spectral field measurements of wave reflection at a steep shore with wave damping chambers, *WIT Transactions on The Built Environment*, 170, [185–191](https://doi.org/10.1016/j.wit.2017.07.001), 2017c.
- Cannaby, H., Palmer, M. D., Howard, T., Briceno, L., Calvert, D., Krijnen, J., Wood, R., Tinker, J., Bunney, C., Harle, J., Saulter, A., O'Neill, C., Bellingham, C., and Lowe, J.: Projected sea level rise and changes in extreme storm surge and wave events during the 21st century in the region of Singapore, *Ocean Science*, 12, 613–632, 2016.
- Cheon, S.-H. and Suh, K.-D.: Effect of sea level rise on nearshore significant waves and coastal structures, *Ocean Eng.*, 114, 280–289, 2016.
- 15 Chini, N. and Stansby, P.: Extreme values of coastal wave overtopping accounting for climate change and sea level rise, *Coastal Eng.*, 65, 27–37, 2012.
- Chini, N., Stansby, P., Leake, J., Wolf, J., Roberts-Jones, J., and Lowe, J.: The impact of sea level rise and climate change on inshore wave climate: A case study for East Anglia (UK), *Coastal Eng.*, 57, 973–984, 2010.
- ~~Forristal, G. Z.: On the Statistical Distribution of Wave Heights in a Storm, *J. Geophys. Res.*, 83, 2353–2358, 1978.~~
- 20 Hanson, H. and Larson, M.: Implications of extreme waves and water levels in the southern Baltic Sea, *Journal of Hydraulic Research*, 46:S2, 292–302, 2008.
- Hawkes, P.: Joint probability analysis for estimation of extremes, *Journal of Hydraulic Research*, 46, 246–256, 2008.
- Hawkes, P., Gouldby, B., Tawn, J., and Owen, M.: The joint probability of waves and water levels in coastal engineering design, *Journal of Hydraulic Research*, 40, 241–251, 2002.
- 25 Johansson, M. M., Boman, H., Kahma, K. K., and Launiainen, J.: Trends in sea level variability in the Baltic Sea, *J. Marine Syst.*, 6, 159–179, 2001.
- Johansson, M. M., Pellikka, H., Kahma, K. K., and Ruosteenoja, K.: Global sea level rise scenarios adapted to the Finnish coast, *J. Marine Syst.*, 129, 35–46, <https://doi.org/10.1016/j.jmarsys.2012.08.007>, 2014.
- Kahma, K., Pettersson, H., Boman, H., and Seinä, A.: Alimmat suositeltavat rakennuskorkeudet Pohjanlahden, Saaristomeren ja Suomenlahden rannikoilla, [In Finnish]., 1998.
- 30 Kahma, K., Pellikka, H., Leinonen, K., Leijala, U., and Johansson, M.: Pitkän aikavälin tulvariskit ja alimmat suositeltavat rakentamiskorkeudet Suomen rannikolla [Long-term flooding risks and recommendations for minimum building elevations on the Finnish coast], <http://hdl.handle.net/10138/135226>, [In Finnish with English summary]., 2014.
- Kahma, K. K. and Pettersson, H.: Wave growth in narrow fetch geometry, *The Global Atmosphere and Ocean System*, 2, 253–263, 1994.
- 35 Kahma, K. K., Björkqvist, J.-V., Johansson, M., Jokinen, H., Leijala, U., Särkkä, J., Tikka, K., and Tuomi, L.: Turvalliset rakentamiskorkeudet Helsingin rannoilla 2020, 2050 ja 2100. [Safe building elevations on the Helsinki coast in 2020, 2050 and 2100], <http://www.hel.fi/static/kv/turvalliset-rakentamiskorkeudet.pdf>, online. 14.2.2016 [In Finnish with English abstract]., 2016.

- ~~Kulikov, E. and Medvedev, I.: Variability of the Baltic Sea Level and Floods in the Gulf of Finland, *Oceanology*, 53, 145–151, 2013.~~
- Leppäranta, M. and Myrberg, K.: *Physical Oceanography of the Baltic Sea*, Springer, 2009.
- [Longuet-Higgins, M.: On the Statistical Distribution of the Heights of Sea Waves, *Journal of Marine Research*, 11, 245–266, 1952.](#)
- Masina, M., Lamberti, A., and Archetti, R.: Coastal flooding: A copula based approach for estimating the joint probability of water levels
5 and waves, *Coastal Eng.*, 97, 37–52, 2015.
- Parjanne, A. and Huokuna, M.: Tulviin varautuminen rakentamisessa – opas alimpien rakentamiskorkeuksien määrittämiseksi ranta-alueilla
[Flood preparedness in building – guide for determining the lowest building elevations in shore areas], <http://hdl.handle.net/10138/135189>,
[In Finnish with English summary]., 2014.
- Pellikka, H., Rauhala, J., Kahma, K., Stipa, T., Boman, H., and Kangas, A.: Recent observations of meteotsunamis on the Finnish coast,
10 *Natural Hazards*, 74, 197–215, 2014.
- Pellikka, H., Leijala, U., Kahma, K. K., Leinonen, K., and Johansson, M. M.: Future probabilities of [sea floods on the Finnisheastcoastal
floods in Finland](#), *Continental Shelf Research*, ~~submitted, 2017-~~ [157, 32–42](#), <https://doi.org/10.1016/j.csr.2018.02.006>, [2018](#).
- Pettersson, H., Lindow, H., and Brüning, T.: Wave climate in the Baltic Sea 2012, [http://www.helcom.fi/baltic-sea-trends/
environment-fact-sheets/](http://www.helcom.fi/baltic-sea-trends/environment-fact-sheets/), online. 15.9.2017, 2013.
- 15 Pindsoo, K. and Soomere, T.: Contribution of wave set-up into to the total water level in the Tallinn area, *Proceedings of the Estonian
Academy of Sciences*, 64, 338–348, 2015.
- Prime, T., Brown, J. M., and Plater, A.: Flood inundation uncertainty: The case of a 0.5% annual probability flood event, *Environmental
Science & Policy*, 59, 1–9, 2016.
- Saaranen, V., Lehmuskoski, P., Rouhiainen, P., Takalo, M., Mäkinen, J., and Poutanen, M.: The new Finnish height reference N2000, in:
20 Drewes, H. (ed.), *Geodetic Reference Frames: IAG Symposium Munich, Germany, 9-14 October 2006*, Springer, pp. 297–302, 2009.
- Särkkä, J., Kahma, K. K., Kämäräinen, M., Johansson, M. M., and Saku, S.: Simulated extreme sea levels at Helsinki, *Boreal Environment
Research*, 22, 299–315, 2017.
- Schay, G.: *Introduction to Probability with Statistical Applications*, Springer International Publishing, Switzerland,
<https://doi.org/10.1007/978-3-319-30620-9>, 2016.
- 25 Soomere, T., Pindsoo, K., Bishop, S., Käärd, A., and Valdmann, A.: Mapping wave set-up near a complex geometric urban coastline, *Natural
Hazards and Earth System Sciences*, 13, 3049–3061, 2013.
- Suursaar, Ü., Kullas, T., Otsmann, M., Saaremäe, I., Kuik, J., and Merilain, M.: Cyclone Gudrun in January 2005 and modelling its hydro-
dynamic consequences in the Estonian coastal waters, *Boreal Environment Research*, 11, 143–159, 2006.
- Tõnisson, H., Orviku, K., Jaagus, J., Suursaar, Ü., Kont, A., and Rivis, R.: Coastal damages on Saaremaa Island, Estonia, caused by the
30 extreme storm and flooding on January 9, 2005, *Journal of Coastal Research*, 24, 602–614, 2008.
- Tuomi, L., Kahma, K., and Pettersson, H.: Wave hindcast statistics in the seasonally ice-covered Baltic Sea, *Boreal Environ. Res.*, 16(6),
451–472, 2011.
- Tuomi, L., Pettersson, H., Fortelius, C., Tikka, K., Björkqvist, J.-V., and Kahma, K.: Wave modelling in archipelagos, *Coastal Engineering*,
83, 205–220, 2014.
- 35 Wahl, T., Mudersbach, C., and Jensen, J.: Assessing the hydrodynamic boundary conditions for risk analyses in coastal areas: a multivariate
statistical approach based on Copula functions, *Natural Hazards and Earth System Sciences*, 12, 495–510, 2012.
- Witting, R.: *Tidvattnen i Östersjön och Finska Viken*, Fennia, 29:2, 1911.